

ADSORPTION OF Fe[III] ON CELLULOSE USING D-VALINE AS FACILITATING AGENT

*Dissertation submitted in Partial fulfillment for the requirements for the award of
degree of*

Bachelor of Science in CHEMISTRY

By

- | | |
|---------------------|-----------------------------|
| 1. K.Dheeraj Kumar, | B.Sc (Chemistry) , III Year |
| 2. G.Laxmi kanth, | B.Sc (Chemistry) , III Year |
| 3. K.Narasimha, | B.Sc (Chemistry) , III Year |
| 4. G.Omkar, | B.Sc (Chemistry) , III Year |
| 5. D.Anil, | B.Sc (Chemistry) , III Year |
| 6. A.Jeremiah, | B.Sc (Chemistry) , III Year |

Under the Guidance:

**Dr. K.ABHIJIT
HEAD
DEPARTMENT OF CHEMISTRY**



Tara Government College, Sangareddy(A)

2021-22

CERTIFICATE

*This is to certify that the project work entitled “**ADSORPTION OF Fe[III] ON CELLULOSE USING D-VALINE AS FACILITATING AGENT**” is presented by B.Sc (CHEMISTRY) students in partial fulfillment of the requirements for the degree of Bachelor of Science in Chemistry by the Tara Govt. College, Sangareddy(A) (Affiliated to Osmania University, Hyderabad) during the academic year 2021-2022.*

The results embodied in this report have not been to any other University or Institution for the award of any degree.

(Dr.K.ABHIJIT)

**Project Supervisor & Head, Department of Chemistry
Tara Government College, Sangareddy(A)**

EXTERNAL EVALUATOR

ACKNOWLEDGEMENTS

*We express my deep gratitude to my research supervisor **Dr.K.Abhijit**, Head, Department of Chemistry, Tara Govt. College, Sangareddy(A)-502001, INDIA for his inspiring guidance during the course of the Project work. The continuous encouragement extended by him propelled me to update my research skills and pedigree to engage in fruitful research.*

*We wish to express our gratitude to **Smt. M.Praveena**, Principal, Tara Govt. College, Sangareddy(A)-502001, INDIA for her constant support, cooperation and suggestions during the research work. We wish to express my sincere thanks to **K.Sreedhar**, Asst. Professor, Department of Chemistry for providing me facilities, help and support for the entire research work.*

*We express our special thanks to **MART Specialities Lab, Hyderabad** for providing technical assistance in Atomic absorption spectrometric analysis.*

Finally, we take this opportunity to thank one and all that has directly or indirectly helped me in completing the task.

1. **K.Dheeraj Kumar**, B.Sc (Chemistry) , III Year
2. **G.Laxmi kanth**, B.Sc (Chemistry) , III Year
3. **K.Narasimha**, B.Sc (Chemistry) , III Year
4. **G.Omkar**, B.Sc (Chemistry) , III Year
5. **D.Anil**, B.Sc (Chemistry) , III Year
6. **A.Jeremiah**, B.Sc (Chemistry) , III Year

DECLARATION

*We hereby declare that the project report entitled “**ADSORPTION OF Fe[III] ON CELLULOSE USING D-VALINE AS FACILITATING AGENT**” is the work done by us in the campus at Department of Chemistry, Tara Government College, Sangareddy(A) during the academic year 2021-2022 and is submitted in partial fulfillment of the requirements for the degree of Bachelor of Science by Tara Govt. College, Sangareddy(A) (Affiliated to Osmania University, Hyderabad) during the academic year 2021-2022.*

S.No.	Name of the Student	Roll Number	Group	Year	Signature
1	K.Dheeraj Kumar	605819578017	BSc Mccs	III	
2	G.Laxmi kanth	605819578012	BSc Mccs	III	
3	K.Narasimha	605819578016	BSc Mccs	III	
4	G.Omkar	605819578014	BSc Mccs	III	
5	D.Anil	605819578009	BSc Mccs	III	
6	A.Jeremiah	605819578001	BSc Mccs	III	

**TARA GOVERNMENT COLLEGE, SANGAREDDY – 502 001
(AUTONOMOUS)**

BONAFIDE CERTIFICATE

*Certified that the project report "ADSORPTION OF Fe[III] ON
CELLULOSE USING D-VALINE AS FACILITATING AGENT" is the
bonafidework of*

- | | |
|----------------------|-----------------------------|
| 1. K. Dheeraj Kumar, | B.Sc (Chemistry) , III Year |
| 2. G. Laxmi kanth, | B.Sc (Chemistry) , III Year |
| 3. K. Narasimha, | B.Sc (Chemistry) , III Year |
| 4. G. Omkar, | B.Sc (Chemistry) , III Year |
| 5. D. Anil, | B.Sc (Chemistry) , III Year |
| 6. A. Jeremiah, | B.Sc (Chemistry) , III Year |

who carried out the project work under my supervision.

*Dr. K. ABHIJIT
PROJECT SUPERVISOR*

*Smt. M. PRAVEENA
PRINCIPAL*

CONTENTS

S.No.	CHAPTERS	Pg.No.
1	INTRODUCTION	1-5
2	ADSORPTION OF HEAVY METALS FROM DILUTE SOLUTIONS	6-12
3	ATOMIC ABSORPTION SPECTROMETRY	13-20
4	METHODOLOGY	21-36
5	RESULTS AND DISCUSSION	37-52

Chapter-I

INTRODUCTION

ADSORPTION

Adsorption is a process in which solids come into contact with liquids or gases, and the mass transfer occurs from liquids to solids. Desorption is the reversal of this action. Adsorption operations take advantage of a solid's capacity to concentrate certain chemicals from a fluid on to its surface. Adsorbate refers to the adsorbed substance, while adsorbent refers to the solid substance. The following are some examples of solid-liquid and solid-gas applications:

- Removing dissolved moisture from gasoline.
- Decolorization of sugar solutions and petroleum products.
- Removing noxious odors and tastes from water. Dehumidification of air and gases is one of the solid-gas activities.
- To fractionate mixtures of hydrocarbon gases such as methane, ethane, and propane.
- To remove undesirable odors and contaminants from gases.
- To recover valuable solvent vapors from dilute gas mixtures.

NATURE OF ADSORBENTS

Adsorbents are typically granular in nature, ranging in size from 0.5 mm to 12 mm. They can't have a lot of pressure decrease or get swept away by a fast-moving stream. During handling, they must maintain their shape and size. They'll need a lot of pores and a lot of surface area per unit mass.

Some of the commonly used adsorbents, their sources and applications are given below:

S. No.	Adsorbent	Source	Application
1.	Fuller's earth	Naturally occurring clay is heated and dried to get a porous structure.	De-colorizing, drying of lubricating oils, kerosene and engine oils.
2.	Activated charcoal	Bentonite or other activated clay which are activated by treatment with sulfuric acid and further washing, drying and crushing.	Used for de-colorizing petroleum products.
3.	Bauxite	A naturally occurring hydrated alumina, activated by heating at 230-815	Used for de-colorizing petroleum products and for drying gases.

4.	Alumina	A hard hydrated aluminium oxide, which is activated by heating to drive off the moisture and then crushed to desired size.	Used as desiccant.
5.	Bone-char	Obtained by destructive distillation of crushed bones at 600-900	Used for refining sugar and can be reused after washing and burning.
6.	Silica gel	A hard granular and porous product obtained from sodium silicate solution after treatment with acid. Normally has 4 to 7% water in the product.	Dehydration of gases and liquids, and separation of gas-liquid hydrocarbon mixture.

7.	Activated carbon	<p>(1) Vegetable matter is mixed with calcium chloride, carbonized and finally the inorganic compounds are leached away.</p> <p>(2) Organic matter is mixed with porous pumice stones and then heated and carbonized to deposit the carbonaceous matter throughout the porous particle.</p> <p>(3) Carbonizing substances like wood, sawdust, coconut shells, fruit pits, coal, lignite and subsequent activation with hot air steam. It is available in granular or pelleted form.</p>	<p>De-colorizing of sugar solutions, chemicals, drugs, water purification, refining of vegetable and animal oils, recovery of gold and silver from cyanide ore-leach solution, recovery of solvent vapour from gas-mixtures, collection of gasoline hydro-carbons from natural gas, fractionation of hydrocarbon gases.</p>
8.	Molecular sieves	<p>These are porous synthetic zeolite crystals, metal alumino-silicates.</p>	<p>Dehydration of gases and liquids, and separation of gas-liquid hydrocarbon mixture.</p>

SIGNIFICANCE OF RESEARCH PROBLEM

Cellulose can be used for adsorption of heavy metals owing to its polyhydric functional groups which will be a fetching tool to develop eco-friendly remediation strategy. Mean while, there is a need to improve the adsorption efficacy of cellulose by the incorporation of facilitating agents to design and develop standardized heavy metal remediation technology. For this purpose organic ligands will be useful to bring the metal-adsorbent linkages by stabilizing the metal complexes which will bind to the adsorbent more covalently.

OBJECTIVE OF THE PROJECT

To evaluate the impact of D-Valine as facilitating agent in the adsorption of Fe (III) from aqueous solution by Cellulose as an adsorbent to develop efficient remediation technology using concept of Coordination chemistry.

Chapter-II

ADSORPTION OF HEAVY METALS FROM DILUTE SOLUTIONS

The phrase "heavy metals" refers to a collection of metals and metalloids that have an atomic density more than 6 g cm^{-3} . Although it is a broad phrase, it is typically used to refer to elements like Cd (cadmium), Cr (chromium), Cu (copper), Hg (mercury), Ni (nickel), Pb (lead), and Zn (zinc) that are commonly related with pollution and toxicity problems. Heavy metals, unlike most organic contaminants, occur naturally.

Each of these elements has a range of normal background concentrations in soils, sediments, waterways, and living creatures because they occur naturally in rock-forming and ore minerals. Significant amounts of various heavy metals are produced each year from the mining of their respective ores. Approximately 14,500 10³ tonnes of copper were produced in 2004. (US Geological Survey, 2004). Soils, sediments, waterways, and live species all play a role in the environment. Significant amounts of various heavy metals are produced each year from the mining of their respective ores.

Metals used in industry and other domestic processes (e.g., burning fossil fuels, incineration of wastes, automobile exhausts, smelting processes, and the use of sewage sludge as a landfill material and fertiliser) have released large amounts of potentially toxic heavy metals into the atmosphere, as well as into aquatic and terrestrial environments. Cd, Pb, and Zn are common hazardous metals released into the environment. Cu, Ni, Cr, Co, Zn, and Pb are some of the most common metals (Babich et al., 1985). Table 1 shows the industrial sources of a variety of metals emitted, as well as the potential for contamination.

While many heavy metals are required by plants as micronutrients, larger quantities have been linked to a variety of harmful effects. Lead causes encephalopathy, cognitive impairment, behavioural problems, renal damage, anaemia, and reproductive system toxicity at high exposure levels (Pagliuca and Mufti, 1990). In its hexavalent state, chromium is well acknowledged to be hazardous (Rowbotham et al., 2000). Exposure to Cr (VI) compounds has been linked to a greater incidence of respiratory malignancies in humans (IARC, 1990). Cadmium has been linked to nephrotoxic effects, especially at high levels of exposure; long-term exposure may also induce bone damage (Friberg, 1985). Neurobehavioural problems and developmental abnormalities, such as dyslexia, attention deficit hyperactivity disorder, and intellectual retardation, can be caused by high mercury levels (Weiss and Landrigan, 2000). Copper poisoning can cause weakness, tiredness, and anorexia, as well as damage to the stomach and intestines (Theophanides and Anastassopoulou, 2002). Nordberg et al. go into great length about the toxicity of nickel and other heavy metals (2007)

Table : Significant anthropogenic sources of metals in the environment.

Industry	Metals	Pollution Arising	Reference
Metalliferous mining	Cd,Cu,Ni,Cr,Co,Zn	Acid mine drainage, tailings, slag heaps	Babich et al.(1985) Aswathanarayana(2003)
Agriculture materials Fertilisers	Cd,Cr,Mo,Pb,U,V,Zn	Run-off, surface and groundwater contamination, plant bioaccumulation	Nicholson et al.(2003) Otero et al.(2005)
Manures sewage sludge	Zn,Cu,Ni,Pb,Cd,Cr,As,Hg	Landspreading threat to ground and surface water	Nicholson et al.(2003) Cheung and Wong (1983) Walter et al.(2006)

Metallurgical industries Specialist alloys and steels	Pb,Mo,Ni,Cu,Cd,As,Te,U, Zn	Manufacture, disposaland recycling of metals, Tailings and slag heaps	Alloway and Ayres (1993) Rule et al (2006) Cheng (2003)
Waste disposal Landfill leachate	Zn,Cu,Cd,Pb,Ni,Cr,Hg	Landfill leachate, contamination of ground and surface	Kjeldson et al.(2002) Fernandez et al.(2005)
Electronics	Pb,Cd,Hg,Pt,Au,Cr,As,Ni, Mn	Aqueous and solid metallic waste food manufacturing and recycling process	Veglio et al. (2003)
Metal finishing industry Electroplating	Cr,Ni,Zn,Cu	Liquid effluents from plating processes	Castelblanque and salimbeni(2004) Zhao et al.(1999) Alvarez-Ayuso et al.(2003)
Miscellaneous sources Batteries	Pb,Sb,Zn,Cd,Ni,Hg	Waste battery fluid, contamination of soil and groundwater	EU Directorate general of the Environment (2004)
Paints and pigments	Pb,Cr,As,Ti,Ba,Zn	Aqueous waste from manufacture, old paint deterioration and soil pollution	Davis and Burns (1999) Barnes and Davis (1996) Monken(2000)

Both the solvent and the solute are adsorbed whenever a mixture of solute and solvent is adsorbed using an adsorbent. As a result, only relative or apparent solute adsorption can be determined. As a result, treating a known volume of solution of original concentration C with a known weight of adsorbent is standard procedure. Let C^* be the solution's final equilibrium solute concentration. If v is the volume of solution per unit mass of adsorbent (cc/g), and C and C^* are the starting and equilibrium concentrations (g/cc) of the solute, then the apparent adsorption of the solute per unit mass of adsorbent is $v(C - C^*)$, (g/g), neglecting any volume change. This statement is most useful in the case of dilute solutions. The C^* value is determined by the temperature, nature, and properties of the adsorbent when the proportion of the original solvent that can be adsorbed is tiny. The Freundlich adsorption isotherm, $C^* = K[v(C - C^*)]^n$, represents the adsorption phenomena in dilute fluids across a small concentration range. The Freundlich adsorption equation is especially useful in situations where the identification of the solute is unknown, such as the removal of colouring substances from sugar solutions, oils, and other liquids. A spectrophotometer or colorimeter can quickly determine the colour composition of the solute. In worked example 2, the interpretation of this data is demonstrated. Adsorption is good if the value of n is high, say 2 to 10. If it's between 1 and 2, it's relatively challenging, and if it's less than 1, it's easy and it indicates poor adsorption characteristics. Freundlich adsorption equation is also useful in such a case where the actual identification of solute is not known, e.g. removal of colouring substance from sugar solutions, oils etc. A typical adsorption isothermal for the adsorption of various adsorbents A, B and C in dilute solution at the same temperature for the same adsorbent is represented in a graph.

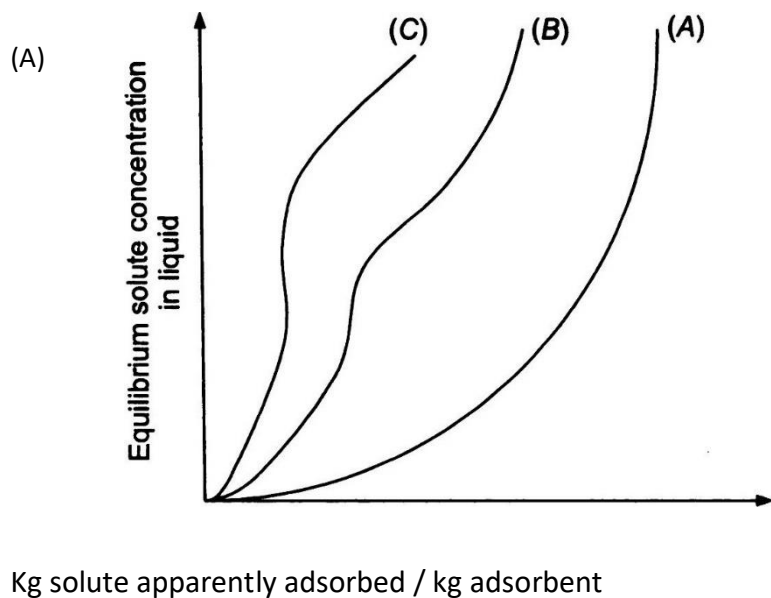

METAL COMPLEXES OF AMINO ACIDS

Transition metal amino acid complexes are a large family of coordination complexes containing the conjugate bases of the amino acids, the 2-aminocarboxylates. Amino acids are prevalent in nature, and all of them function as ligands toward the transition metals. Not included in this article are complexes of the amides (including peptide) and ester derivatives of amino acids. Also excluded are the polyamino acids including the chelating agents EDTA and NTA.

Most commonly, amino acids coordinate to metal ions as N,O bidentate ligands, utilizing the amino group and the carboxylate. They are "L-X" ligands. A five-membered chelate ring is formed. The chelate ring is only slightly ruffled at the sp^3 -hybridized carbon and nitrogen centers. For those amino acids containing coordinating substituents, the resulting complexes are more structurally diverse since these substituents can coordinate. Histidine, aspartic acid, methionine, and cysteine sometimes form

tridentate N,N,O, N,O,O, S,N,O, and S,N,O complexes, respectively. Using kinetically inert metal ions, complexes containing monodentate amino acids have been characterized. These complexes exist in either the N or the O linkage isomers. It can be assumed that such monodentate complexes exist transiently for many kinetically labile metal ions (e.g. Zn^{2+}). Mixing simple metal salts with solutions of amino acids near neutral or elevated pH often affords bis- or tris complexes. For metal ions that prefer octahedral coordination, these complexes often adopt the stoichiometry $\text{M}(\text{aa})_3$ (aa = amino carboxylate, such as glycinate, $\text{H}_2\text{NCH}_2\text{CO}_2^-$). Complexes of the 3:1 stoichiometry have the formula $[\text{M}(\text{O}_2\text{CC}(\text{R})\text{HNH}_2)_3]^z$. Such complexes adopt octahedral coordination geometry. These complexes can exist in facial and meridional isomers, both of which are chiral. The stereochemical possibilities increase when the amino acid ligands are not homochiral. Complexes with the 2:1 stoichiometry are illustrated by copper(II) glycinate $[\text{Cu}(\text{O}_2\text{CC}(\text{R})\text{HNH}_2)_2]$, which exists both in anhydrous and pentacoordinate geometries. When the metal is square planar, these complexes can exist as cis and trans isomers. The stereochemical possibilities increase when the amino acid ligands are not homochiral. Homoleptic complexes are also known where the amino carboxylate is tridentate amino acids. One such complex is $\text{Ni}(\kappa^3\text{-histidinate})_2$. D-Valine can easily be involved in M-L complex formation due to its functional flexibility. Moreover its water solubility encourages the metal-ligand complex formation under aqueous conditions.

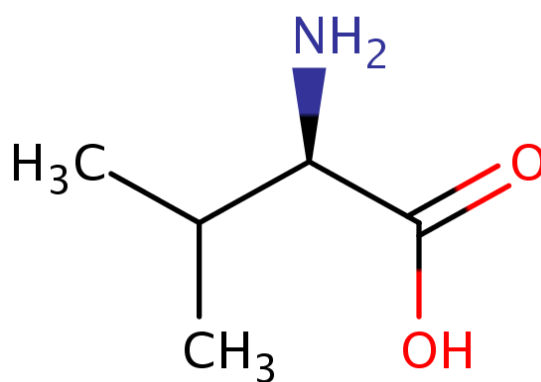

D-Valine

CELLULOSE AS ADSORBENT

Cellulose is the most plentiful and renewable polymer material available on the planet. According to estimates, deterioration and soil pollution Photosynthesis produces 10^{11} – 10^{12} tonnes of cellulose every year in a relatively pure form, such as in the seed hairs of cotton plants, but it is more commonly mixed with lignin and other polysaccharides (so-called hemicelluloses) in the cell walls of woody plants (Klemm et al., 2002). For thousands of years, cellulose has been utilised as an energy source, a building material, and a clothing material in the form of wood and cotton.

As a carbohydrate polymer, cellulose has a molecular structure that is made up of repeating b-D-glucopyranose units that are covalently linked by acetal functionalities between the OH groups of the C4 and C1 carbon atoms (b-1,4-glucan). Cellulose is a long, linear-chain polymer with a lot of hydroxyl groups (three per anhydroglucose (AGU) unit) and the 4C1 conformation. Every second AGU unit is rotated 180 degrees in the plane to accommodate the preferred bond angles. The number of constituent AGU units (degree of polymerization, DP) determines the length of the polymeric cellulose chain, which varies depending on the origin and treatment of the cellulose raw material (Klemm et al., 2002).

Cellulose has a ribbon form that allows it to twist and bend in directions other than the plane, making it a fairly flexible molecule. Due to the presence of hydroxyl (–OH) groups that protrude from the chain and create intermolecular hydrogen bonds, there is a relatively strong interaction between neighbouring cellulose molecules in dry fibres. Each chain of cellulose regenerated fibres contains 250–500 repeating units (Klemm et al., 2002). The hydrophilicity, chirality, and degradability features of cellulose are due to this molecular structure. Chemical reactivity is mostly determined by the OH groups' high donor reactivity.

Chapter-III

ATOMIC ABSORPTION SPECTROMETRY

Atomic absorption spectrometry (AAS) is an analytical technique that measures the concentrations of elements. Atomic absorption is so sensitive that it can measure down parts per billion of a gram ($\mu\text{g dm}^{-3}$) in a sample. The technique makes use of the wavelengths of light specifically absorbed by an element. They correspond to the energies needed to promote electrons from one energy level to another, higher, energy level.

Atomic absorption spectrometry has many uses in different areas of chemistry.

Clinical analysis: Analysing metals in biological fluids such as blood and urine.

Environmental analysis: Monitoring our environment- eg finding out the levels of various elements in rivers, seawater, drinking water, air, petrol and drinks such as wine, beer and fruit drinks.

Pharmaceuticals: In some pharmaceutical manufacturing processes, minute quantities of a catalyst used in the process (usually a metal) are sometimes present in the final product. By using AAS the amount of catalyst present can be determined.

Industry: Many raw materials are examined and AAS is widely used to check that the major elements are present and that toxic impurities are lower than specified- eg in concrete, where calcium is a major constituent, the lead level should be low because it is toxic.

Mining: By using AAS the amount of metals such as gold in rocks can be determined to see whether it is worth mining the rocks to extract the gold.

HOW IT WORKS

Atoms of different elements absorb characteristic wavelengths of light. Analysing a sample to see if it contains a particular element means using light from that element. For example with lead, a lamp containing lead emits light from excited lead atoms that produce the right mix of wavelengths to be absorbed by any lead atoms from the sample. In AAS, the sample is atomized- i.e. converted into ground state free atoms in the vapour state- and a beam of electromagnetic radiation emitted from excited lead atoms is passed through the vaporized sample. Some of the radiation is absorbed by the lead atoms in the sample. The greater the number of atoms there is in the vapour, the more radiation is absorbed. The amount of light absorbed is proportional to the number of lead atoms. A calibration curve is constructed by running several samples of known lead concentration under the same conditions as the unknown. The amount the standard absorbs is compared with the calibration curve and this enables the calculation of the lead concentration in the unknown sample. Consequently an atomic absorption spectrometer needs the following three components: a light source; a sample cell to produce gaseous atoms; and a means of measuring the specific light absorbed.

THE LIGHT SOURCE

The common source of light is a 'hollow cathode lamp'. This contains a tungsten anode and a cylindrical hollow cathode made of the element to be determined. These are sealed in a glass tube filled with an inert gas- e.g neon or argon- at a pressure of between 1 Nm^{-2} and 5 Nm^{-2} .



The ionization of some gas atoms occurs by applying a potential difference of about 300-400V between the anode and the cathode. These gaseous ions bombard the cathode and eject metal atoms from the cathode in a process called sputtering. Some sputtered atoms are in excited states and emit radiation characteristic of the metal as they fall back to the ground state – $eg Pb^* \rightarrow Pb + h\nu$. The shape of the cathode concentrates the radiation into a beam which passes through a quartz window, and the shape of the lamp is such that most of the sputtered atoms are redeposited on the cathode. A typical atomic absorption instrument holds several lamps each for a different element. The lamps are housed in a rotating turret so that the correct lamp can be quickly selected.

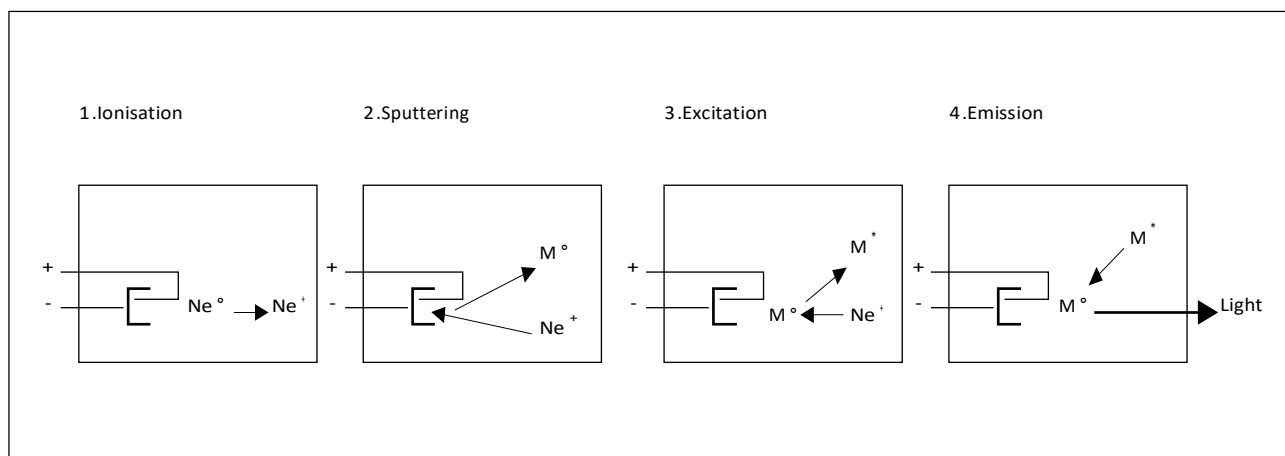

THE OPTICAL SYSTEM AND DETECTOR

A monochromator is used to select the specific wavelength of light –ie spectral line – which is absorbed by the sample, and to exclude other wavelengths. The selection of the specific light allows the determination of the selected element in the presence of others. The light selected by the monochromator is directed onto a detector that is typically a photomultiplier tube. This produces an electrical signal proportional to the light intensity

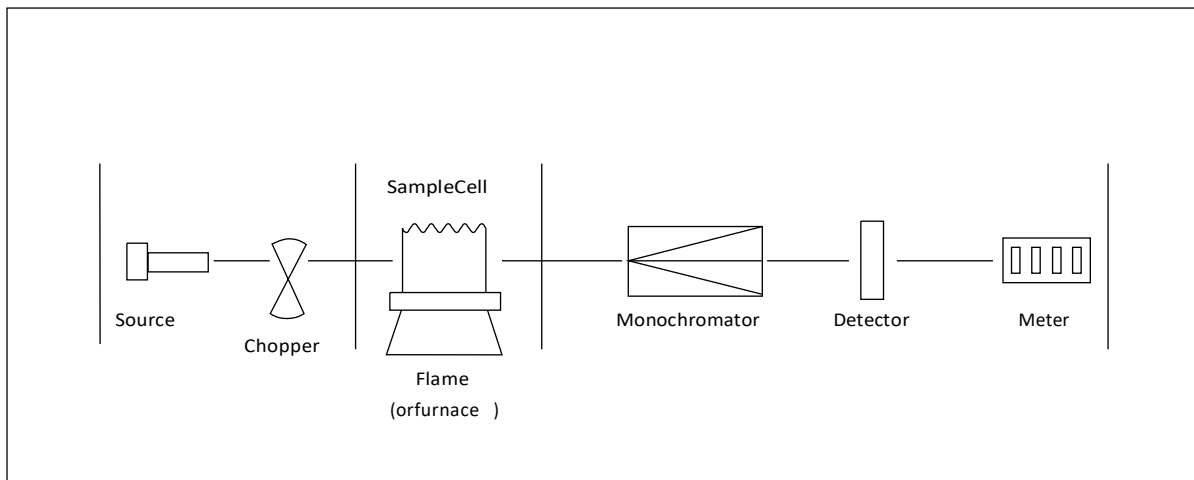

DOUBLE BEAM SPECTROMETERS

Modern spectrometers incorporate a beam splitter so that one part of the beam passes through the sample cell and the other is the reference. The intensity of the light source may not stay constant during an analysis. If only a single beam is used to pass through the atom cell, a blank reading containing no analyte (substance to be analysed) would have to be taken first, setting the absorbance at zero. If the intensity of the source changes by the time the sample is put in place, the measurement will be inaccurate. In the double beam instrument there is a constant monitoring between the reference beam and the light source. To ensure that the spectrum does not suffer from loss of sensitivity, the beam splitter is designed so that as high a proportion as possible of the energy of the lamp beam passes through the sample.

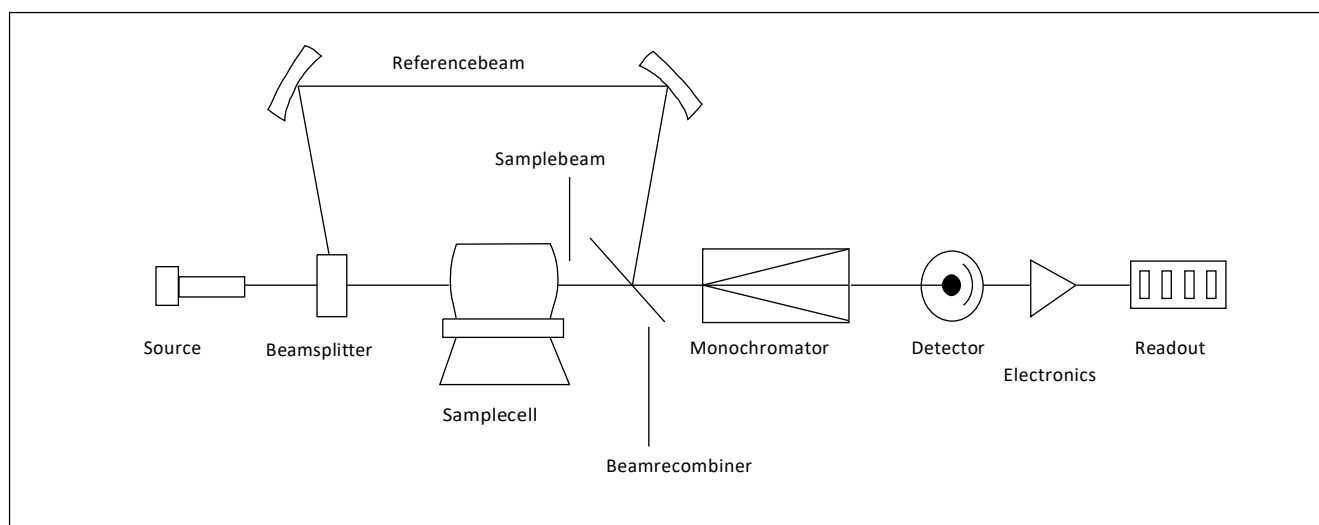

ATOMISATION OF THE SAMPLE

Two systems are commonly used to produce atoms from the sample. Aspiration involves sucking a solution of the sample into a flame; and electrothermal atomisation is where a drop of sample is placed into a graphite tube that is then heated electrically.

Some instruments have both atomisation systems but share one set of lamps. Once the appropriate lamp has been selected, it is pointed towards one or other atomisation system.

FLAME ASPIRATION

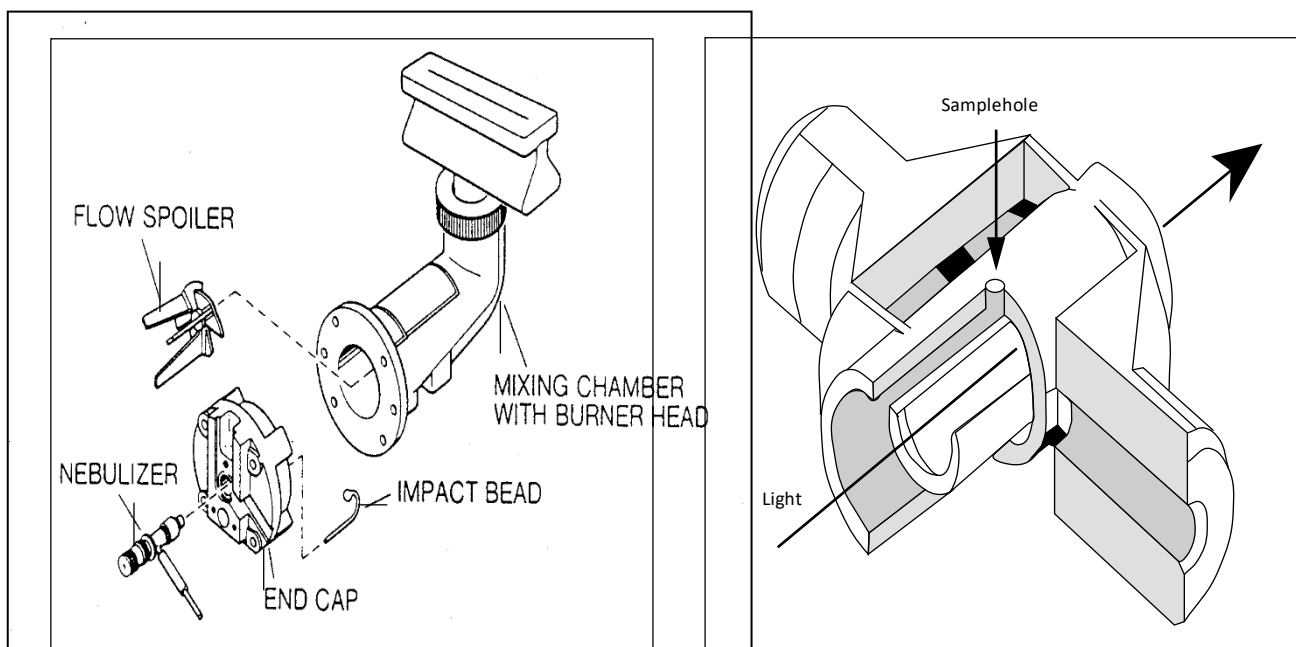

Figure 1

Figure 2

Ethyne/air (giving a flame with a temperature of 2200–2400°C) or ethyne/dinitrogen oxide (2600–2800°C) are often used. A flexible capillary tube connects the solution to the nebuliser. At the tip of the capillary, the solution is ‘nebulised’ –ie broken into small drops. The larger drops fall out and drain off while smaller ones vaporise in the flame. Only ca 1% of the sample is nebulised.

ELECTROTHERMAL ATOMIZATION

25 μl of sample (ca 1/100th of a raindrop) is placed through the sample hole and onto the platform from an automated micropipette and sample changer. The tube is heated electrically by passing a current through it in a pre-programmed series of steps. The details will vary with the sample but typically they might be 30–40 seconds at 150°C to evaporate the solvent, 30 seconds at 600°C to drive off any volatile organic material and char the sample to ash, and with a very fast heating rate (ca 1500 °C s⁻¹) to 2000–2500°C for 5–10 seconds to vaporise and atomise elements (including the element being analysed). Finally heating the tube to a still higher temperature –ca 2700°C – cleans it ready for the next sample. During this heating cycle the graphite tube is flushed with argon gas to prevent the tube burning away. In electrothermal atomisation almost 100% of the sample is atomised. This makes the technique much more sensitive than flame AAS.

SAMPLE PREPARATION

Sample preparation is often simple, and the chemical form of the element is usually unimportant. This is because atomisation converts the sample into free atoms irrespective of its initial state. The sample is weighed and made into a solution by suitable dilution. Elements in biological fluids such as urine and blood are often measured simply after a dilution of the original sample.



When making reference solutions of the element under analysis, for calibration, the chemical environment of the sample should be matched as closely as possible –i.e. the analyte should be in the same compound and the same solvent. Teflon containers may be used when analyzing very dilute solutions because elements such as lead are sometimes leached out of glass vessels and can affect the results

BACKGROUND ABSORPTION

It is possible that other atoms or molecules apart from those of the element being determined will absorb or scatter some radiation from the light source. These species could include unvaporised solvent droplets, or compounds of the matrix (chemical species, such as anions, that tend to accompany the metals being analysed) that are not removed completely. This means that there is a background absorption as well as that of the sample.

One way of measuring and correcting this background absorption is to use two light sources, one of which is the hollow cathode lamp appropriate to the element being measured. The second light source is a deuterium lamp.

The deuterium lamp produces broad band radiation, not specific spectral lines as with a hollow cathode lamp. By alternating the measurements of the two light sources – generally at 50 –100 Hz – the total absorption (absorption due to analyte atoms plus background) is measured with the specific light from the hollow cathode lamp and the background absorption is measured with the light from the deuterium lamp. Subtracting the background from the total absorption gives the absorption arising from only analyte atoms.

CALIBRATION

A calibration curve is used to determine the unknown concentration of an element –eg lead – in a solution. The instrument is calibrated using several solutions of known concentrations. A calibration curve is produced which is continually rescaled as more concentrated solutions are used – the more concentrated solutions absorb more radiation up to a certain absorbance. The calibration curve shows the concentration

against the amount of radiation absorbed in the given figure.(a) The sample solution is fed into the instrument and the unknown concentration of the element-e.g. lead- is then displayed on the calibration curve given in the below figure.(b)

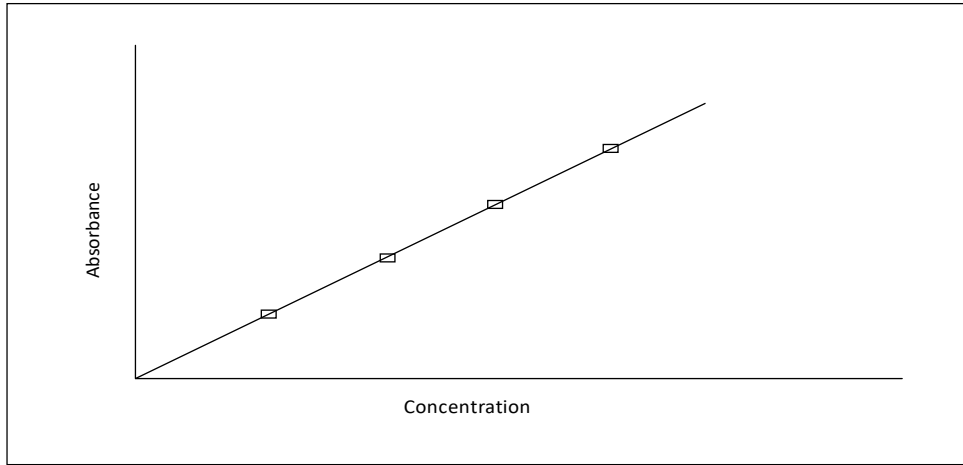

Figure (a)

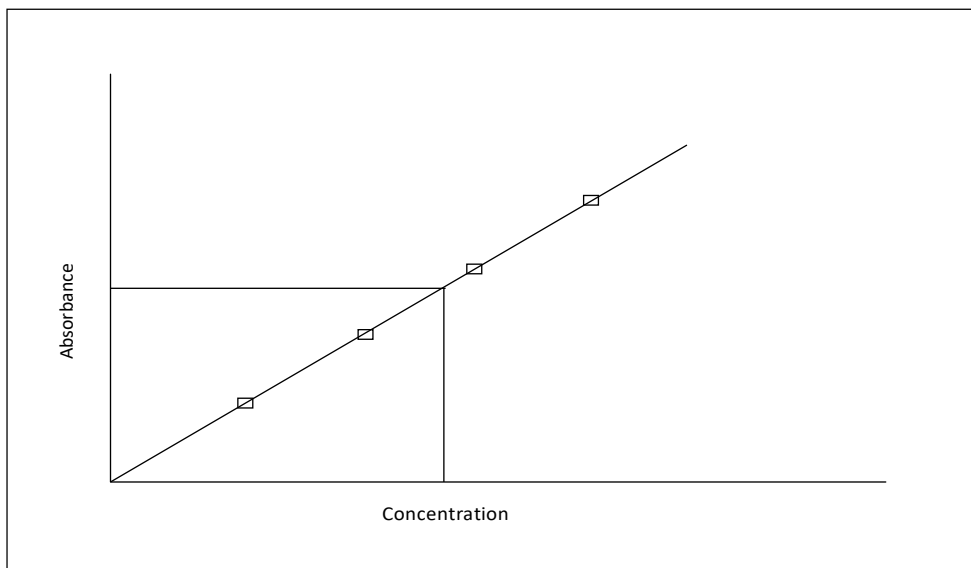

Figure (b)

Chapter-IV

METHODOLOGY

MATERIALS REQUIRED

- Ferric chloride pure Hexahydrate
- D-Valine
- Cellulose
- Volumetric flask
- Digital Weighing Machine
- Watch glasses
- Hot air oven
- Ultra pure water (Demineralized)
- 2% of Nitric acid

PROCEDURE

1. Using a 250ml Volumetric flask prepare a metal ligand solution by adding 100ppm of Ferric chloride Hexahydrate (MOLYCHEM MCR-11580) and 200ppm of D-Valine (Avra N2200133). Prepare 250ml solution by adding Ultra pure water and then keep this system aside for a few hours.
2. Weigh 5 grams of Cellulose (Avra N2001901) using a Digital weighing machine (Citizen Scales(I) PVT LTD CTG302-300) and take this into a beaker.
3. Now add 100ml of the above prepared metal ligand solution into the beaker and stir the mixture well for 10 minutes using a glass rod.

4. Keep this mixture aside for 48 hours without disturbing it as at this step Ferric is going to be adsorbed on Cellulose in the presence of D-Valine which acts as a chelating agent.
5. After completion of 48 hours take the mixture and filter it off using Whatman Grade 1 filter paper and a funnel.
6. After filtration of the mixture again add Ultra pure water for 3 times and then filtrate it to obtain pure concentration of Ferric which is get adsorbed on Cellulose.
7. Collect the filtered Cellulose powder and place it on a watch glass and keep this in a Hot air oven at 60 °C for 10 hours to get rid off moisture present in it.
8. Now weigh each 1 gm of Cellulose in glass vials.
9. Now take a beaker and rinse it with ultra pure water then followed by Nitric acid.
10. Take 0.5 grams of Cellulose sample in the beaker and add 2% of Nitric acid and stir the mixture well for 10-15 minutes.
11. Filter the mixture using Whatman Grade 1 filter paper and again 3 times by using Ultra pure water to obtain pure concentration of Ferric present in the mixture prepared using the sample.
12. Take this collected sample solution and keep this system under AAS (Thermo Scientific iCE 3300)
13. Calculate the concentration of Ferric adsorbed on Cellulose at different ppm levels. Observe the graph obtained and note down the readings of the result we obtained.
14. Same Experiment carried out without the interference/addition of Ligand i.e. D-Valine for Control Experiment.

AA spectrometer



Model no. ICE 33 0

Fume hood



Fe standards with test sample

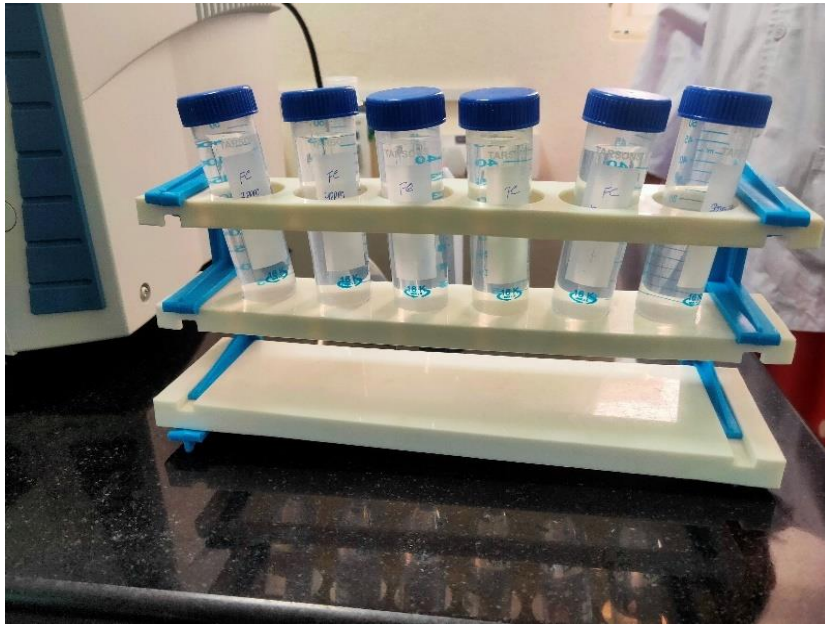

Sample is Taking in to the Machine \



Burning of test sample in AASpectrometer

Values after intake of test samples

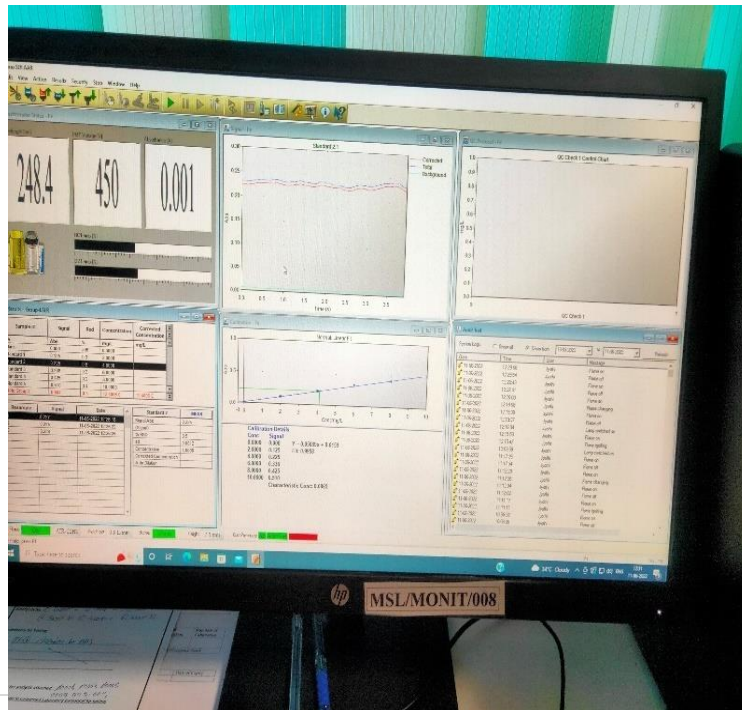

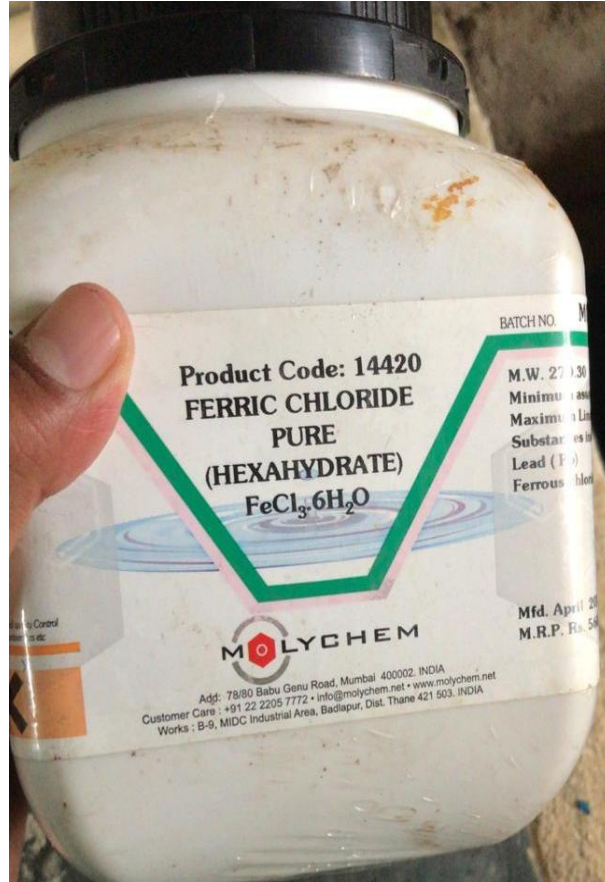

Ferric Chloride (FeCl₃·6H₂O)

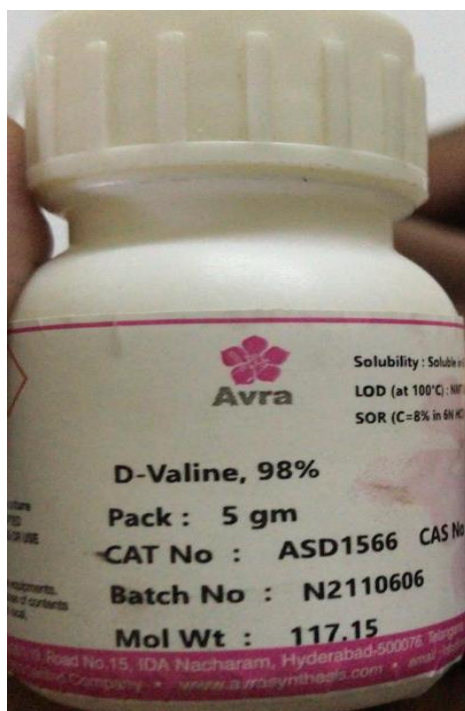

D-VALINE (Avra)

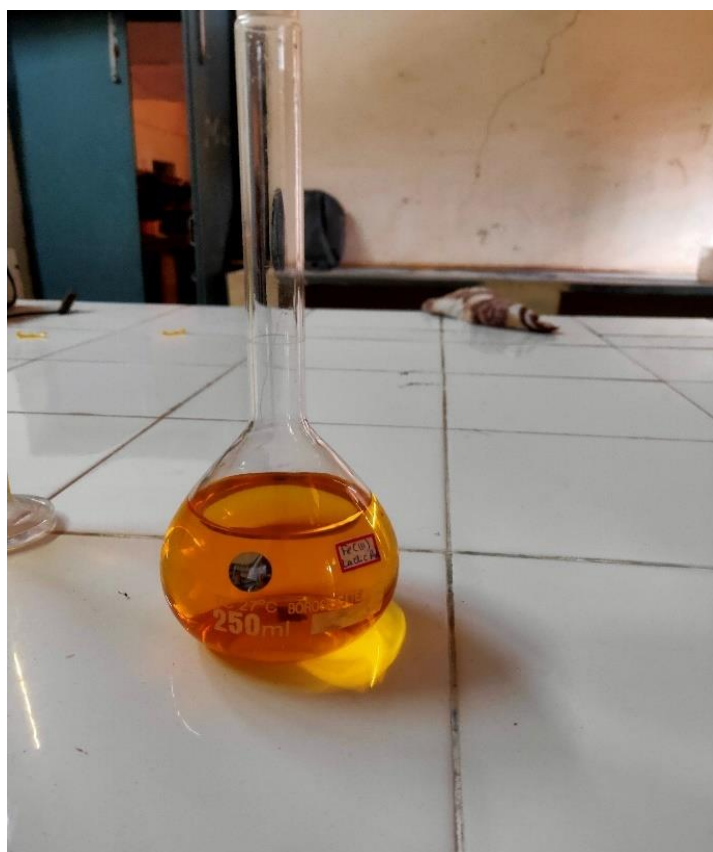

Solution of Fe(III)-D-Valine Solution

Other Apparatus Used



Watch glass



Spatula



Measuring Jar 50 ml



Digital weighing Machine





Filtering the solution



China Dish









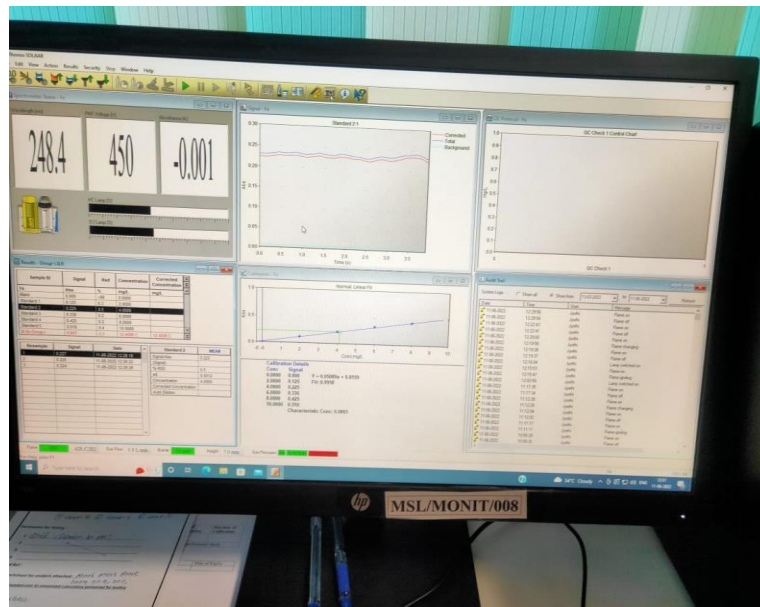

Results obtained on the monitor under AAS Method

Chapter-V

RESULTS AND DISCUSSIONS

From an aqueous solution of the metal ligand solution Fe(III)-D-Valine, Cellulose absorbed **756.5ppm** of iron. When D-Valine is absent, Cellulose only absorbed **715.0ppm**. The AAS data clearly show that the addition of ligands improved the metal adsorption by triggering possible chemical interactions between the adsorbent and adsorbate. Strong coordination bonds between D-Valine and Fe(III) result in the formation of a soluble complex in aqueous solution. By creating chemical bonds, the ligand-capped Fe(III) complex firmly adhered to Cellulose. The AAS data clearly show that **5.804%** more adsorption occurred when D-Valine was included as a chelating agent.

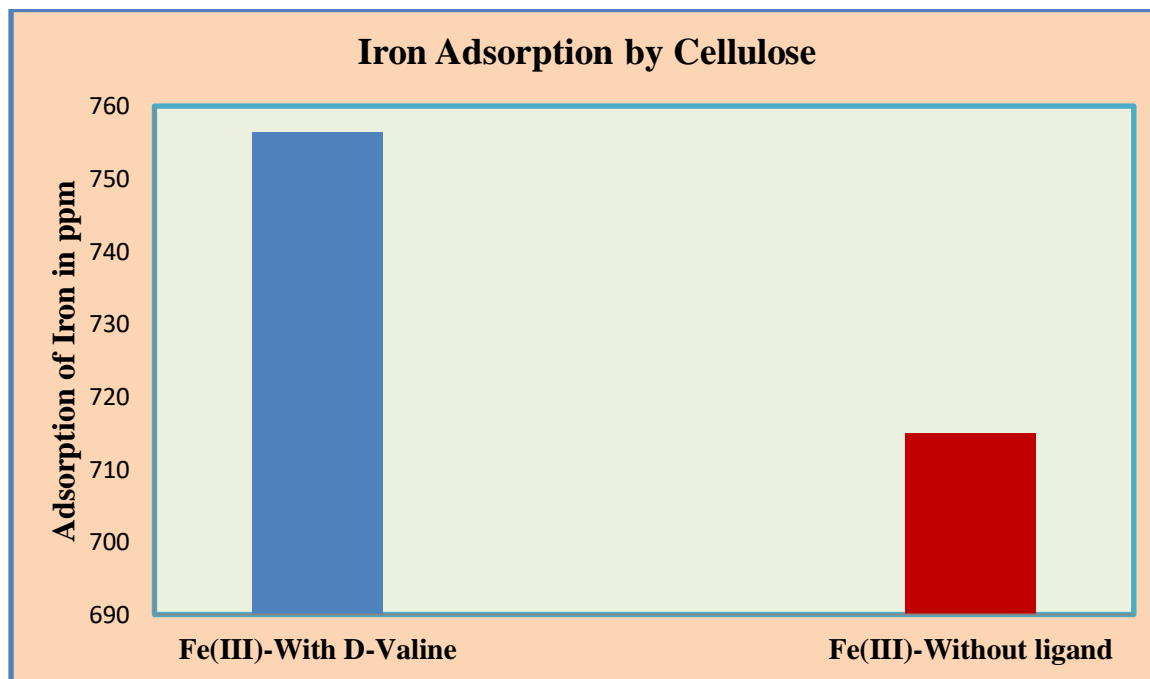

Impact of D-Valine on Adsorption of Fe (III) ions from aqueous solution by Cellulose.

Spectrometer Parameters – Fe:

Element : Fe	Measurement mode : Absorbance	
Wavelength : 248.3nm	Band pass : 0.2nm	Lamp current : 75%
Background correction : D2	High Resolution : Off	Optimise Spectrometer Parameters : No
Signal type : continuous	Resamples : Fast	Number of resamples : 3
Measurement time : 4.0secs	Flier mode : No	
Use RSD Test : No		

Flame Parameters – Fe:

Flame type : Air – C2H2	Fuel Flow : 0.9L/min	Auxiliary Oxidant : Off
Nebuliser Uptake : 4secs	Bunsen Stabilisation : 0mins	Optimise Fuel Flow : No
Burner Height : 7.0mm	Optimise Burner fuel : No	

Calibration Parameters–Fe:

Calibration mode : Normal	Line fit : Linear	Use stored calibration : No
Concentration units : mg/L	Scales units : mg/L	Scaling factor : 1.0000
Acceptable fit : 0.990	Rescale Limits : 10.0%	Failure Action : Flag and Continue
Standard 1 - 2.0000	Standard 4 - 8.0000	
Standard 2 - 4.0000	Standard 5 - 10.0000	
Standard 3 - 6.0000		

Solutions Results–Fe:

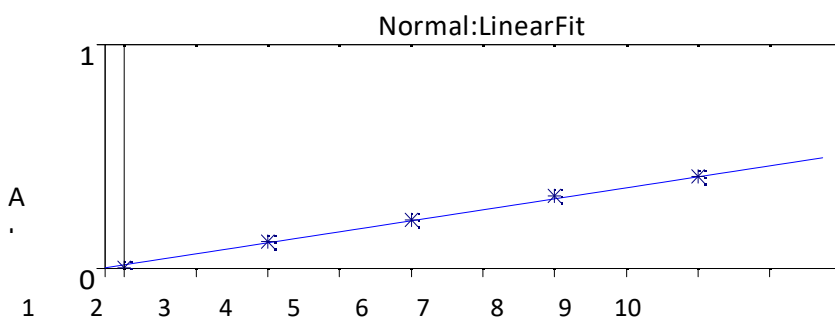

$Y = 0.04924x + 0.0141$

Fit: 0.9965

Characteristic Conc.: 0.0894

Sample ID	Signal	RSD	Conc.
	Abs	%	Mg/L
Fe Blank	0.001	35.6	0.0000
1	0.001	Background: -0.003	
2	0.001	Background: -0.003	
3	0.000	Background: -0.003	
Fe Standard 1	0.120	0.3	2.0000
1	0.120	Background: 0.003	
2	0.119	Background: 0.003	
3	0.120	Background: 0.003	
Fe Standard 2	0.215	0.3	4.0000
1	0.215	Background: 0.004	
2	0.215	Background:0.004	
3	0.216	Background:0.004	
Fe Standard 3	0.322	0.2	6.0000

1	0.323	Background: 0.005	
2	0.322	Background: 0.005	
3	0.322	Background: 0.005	
Fe Standard 4	0.411	0.3	8.0000
1	0.410	Background: 0.005	
2	0.412	Background: 0.005	
3	0.412	Background: 0.005	
Fe Standard 5	0.493	0.1	10.0000
1	0.494	Background: 0.005	
2	0.494	Background: 0.005	
3	0.494	Background: 0.006	
Fe(III)-D-Valine-Cellulose	0.759	0.1	15.1286
1	0.758	Background: 0.003	
2	0.760	Background: 0.003	
3	0.758	Background: 0.004	
Fe(III)-Cellulose (Without Ligand)	0.717	0.1	14.2986 C
1	0.719	Background: 0.004	
2	0.716	Background: 0.003	
3	0.716	Background: 0.004	

Test Results:

S.no	Test Parameters	Sample	Results
01.	Iron by AAS Analysis: (ppm)	Fe(III)-D-Valine – Cellulose Sample	756.5ppm
02.	Iron by AAS Analysis: (ppm)	Fe(III)– Cellulose (control)	715.0 PPM

CONCLUSION

According to the results of the current experiment, D-Valine, which acts as a chelating agent, is crucial to the adsorption of Fe (III) ions from aqueous solution by Cellulose and enhances adsorption by up to **5.804%**. Designing the latest heavy metal remediation systems that employ natural chelating ligands as facilitation agents in metal adsorption processes would benefit from this feature.

REFERENCES

- 1 I. Nakagawa, R. J. Hooper, J. L. Walter and T. J. Lane, *Spectrochim. Acta*, 1966, 21, 1–14.
- 2 M. Tomassetti, E. Cardarelli, R. Curini and G. D'ascenzo, *Thermochim. Acta*, 1987, 113, 243–255.
- 3 M. M. Suvarna, V. S. Panse, U. P. Fulwadva and P. K. Jadhav, *Asian J. Chem.*, 1995, 7(3), 459–499.
- 4 J. G. Shao, Y. X. Yang, B. W. Li, L. P. Zhang, Y. R. Chen and X. L. Liu, *J. Therm. Anal. Calorim.*, 2009, 96(1), 277–285.
- 5 S. Shirazian and S. Gronert, *J. Mol. Struct.: THEOCHEM*, 1997, 397, 107–112.
- 6 T. Dudev and C. Lim, *Annu. Rev. Biophys.*, 2008, 39, 97–116.7 J. J. R. Frausto da Silva and R. J.
- 7 P. Williams, *The biological chemistry of the elements*, Clarendon Press, Oxford, 1991.
8. *Handbook on Metalloproteins*, ed. I. Bertini, A. Sigel and H. Sigel, Marcel Dekker, New York, 2001.
9. T. Dudev and C. Lim, *Chem. Rev.*, 2003, 103, 773–787.

- 10 D. W. Christianson and J. D. Cox, *Annu. Rev. Biochem.*, 1999, 68, 33–57.
- 11 P. M. Kroneck, V. Vortisch and P. Hemmerich, *Eur. J. Biochem.*, 1980, 12, 603–612.
- 12 B. M. Rode, *Peptides*, 1999, 20, 773–786.
- 13 B. M. Rode, J. Bujdak and A. H. Eder, *Trends Inorg. Chem.*, 1993, 3, 45–62.
- 14 E. Constantino, A. Rimola, L. Rodriguez-Santiago and M. Sodupe, *New J. Chem.*, 2005, 29, 1585–1593.
- 15 W. F. DeGrado, C. M. Summa, V. Pavone, F. Nastro and A. Lombardi, *Annu. Rev. Biochem.*, 1999, 68, 779–819.
- 16 Y. Lu, S. M. Berry and T. D. Pester, *Chem. Rev.*, 2001, 101, 3047–3080.
- 17 Y. Lu, *Curr. Opin. Chem. Biol.*, 2005, 9, 118–126.
- 18 J. Xie, W. Liu and P. G. Schultz, *Angew. Chem., Int. Ed.*, 2007, 46, 9239–9242.
- 19 A. L. Garay, A. Pichon and S. L. James, *Chem. Soc. Rev.*, 2007, 36, 846–855.
- 20 X. Q. Xin and L. M. Zheng, *J. Solid State Chem.*, 1993, 106, 451–456.
- 21 S. Mandal, G. Das and H. Askari, *Struct. Chem.*, 2014, 25, 43–51.
- 22 H. Koshima, D. Matsushige, M. Miyauchi and J. Fujita, *Tetrahedron*, 2000, 56, 6845–6852.
- 23 T. Shimo, T. Uezono, T. Obata, M. Yasutake, T. Shinmyozu and K. Somekawa, *Tetrahedron*, 2002, 58, 6111–6116.
- 24 M. R. Wormald, A. J. Petrescu, Y. Pao, A. Glithero, T. Elliott and R. A. Dwek, *Chem. Rev.*, 2002, 102(2), 371–386.
- 25 N. Foloppe, B. Hartmann, L. Nilsson and A. D. MacKerell Jr, *Biophys. J.*, 2002, 82, 1554–1569.
- 26 S. Miertus, E. Scrocco and J. Tomasi, *Chem. Phys.*, 1981, 55(1), 117–129.
- 27 A. D. Becke, *J. Chem. Phys.*, 1993, 98, 5648–5652.
- 28 C. Lee, W. Yang and R. G. Parr, *Phys. Rev. B: Condens. Matter Mater. Phys.*, 1988, 37, 785–789.

- 29 M. J. Frisch, *et al.* *Gaussian 03, Revision D.01*, Gaussian Inc, Wallingford, CT, 2004.
- 30 M. J. Frisch, *et al.* *Gaussian 09, Revision D02*, Gaussian, Wallingford, CT, 2009.
- 31 I. R. Gould and I. H. Hillier, *J. Chem. Soc., Chem. Commun.*, 1993, 951–952.
- 32 M. P. Andersson and P. Uvdal, *J. Phys. Chem. A*, 2005, 109, 2937–2941.
- 33 J. B. Foresman and A. Frisch, *Exploring chemistry with electronic structure methods*, 2nd edn, Gaussian, Inc., Pittsburgh, PA, 1996.
- 34 F. Freeman and K. T. Le, *J. Phys. Chem. A*, 2003, 107, 2908–2918.
- 35 R. Bauernschmitt and R. Ahlrichs, *Chem. Phys. Lett.*, 1996, 256, 454–464.
- 36 M. E. Casida, C. Jamorski, K. C. Casida and D. R. J. Salahub, *J. Chem. Phys.*, 1998, 108, 4439–4449.
- 37 M. A. L. Marques and E. K. U. Gross, *Annu. Rev. Phys. Chem.*, 2004, 55, 427–455.
- 38 E. Runge and E. K. U. Gross, *Phys. Rev. Lett.*, 1984, 52, 997–1000.
- 39 R. E. Stratmann, G. E. Scuseria and M. J. Frisch, *J. Chem. Phys.*, 1998, 109, 8218–8224.
- 40 K. Morokuma, *J. Chem. Phys.*, 1971, 55, 1236–1244.
- 41 F. Freeman and K. T. Le, *J. Phys. Chem. A*, 2003, 107, 2908–2918.
- 42 R. Bauernschmitt and R. Ahlrichs, *Chem. Phys. Lett.*, 1996, 256, 454–464.
- 43 M. E. Casida, C. Jamorski, K. C. Casida and D. R. J. Salahub, *J. Chem. Phys.*, 1998, 108, 4439–4449.
- 44 M. A. L. Marques and E. K. U. Gross, *Annu. Rev. Phys. Chem.*, 2004, 55, 427–455.
- 45 E. Runge and E. K. U. Gross, *Phys. Rev. Lett.*, 1984, 52, 997–1000.
- 46 R. E. Stratmann, G. E. Scuseria and M. J. Frisch, *J. Chem. Phys.*, 1998, 109, 8218–8224.
- 44 S. A. Zabin and C. R. Jejurkar, *Asian J. Chem.*, 1995, 7(3), 542–550.
- 45 S. Kapoor and M. S. Sastry, *Proc. - Indian Acad. Sci., Chem. Sci.*, 2000, 112, 459–463.
- 46 O. Zulbiye, Z. Huseyin and S. Mehmet, *Turk. J. Chem.*, 2011, 35, 905–914.
- 47 S. V. Sanap and R. M. Patil, *Res. J. Pharm. Sci.*, 2013, 2(1), 1–10.

- 48 K. Nakamoto, Y. Morimoto and A. E. Martell, *J. Am. Chem. Soc.*, 1961, 83, 4528–4532.
- 49 P. R. Reddy, M. Radhika and P. Manjula, *J. Chem. Sci.*, 2005, 117(3), 239–246.
- 50 M. M. Mashaly, Z. H. Abd-Elwahab and A. A. Faheim, *J. Chin. Chem. Soc.*, 2004, 51, 901–915.
- 51 S. A. Zabin and C. R. Jejurkar, *Asian J. Chem.*, 1995, 7(3), 542–550.
- 52 S. Kapoor and M. S. Sastry, *Proc. - Indian Acad. Sci., Chem. Sci.*, 2000, 112, 459–463.
- 53 O. Zulbiye, Z. Huseyin and S. Mehmet, *Turk. J. Chem.*, 2011, 35, 905–914.
- 54 E. L. S. Gomes and O. L. Casagrande Jr, *Thermochim. Acta*, 1999, 331, 87–91.
- 55 J. M. Berg and D. L. Merkle, *J. Am. Chem. Soc.*, 1989, 111, 3759–3761.
- 56 N. C. Polfer, J. Oomens, D. T. Moore, G. von Helden, G. Meijer and R. C. Dunbar, *J. Am. Chem. Soc.*, 2006, 128, 517–525.
- 57 S. G. Stepanian, I. D. Reva, E. D. Radchenko, M. T. S. Rosado, M. L. T. S. Duarte, R. Fausto and L. Adamowicz, *J. Phys. Chem. A*, 1998, 102, 1041–1054.
- 58 K. Fukui, T. Yonezawa and H. Shingu, *J. Chem. Phys.*, 1952, 20, 722–725.
- 59 M. T. Baei and S. Z. Sayyed-Alangi, *Eur. J. Chem.*, 2012, 9, 1244–1250.
- 60 C. L. Brooks III, M. Karplus and B. M. Pettitt, *Proteins: a theoretical perspective of dynamics, structure, and thermodynamics*, Wiley, New York, 1988.
- 61 M. Remko, D. Fitz and B. M. Rode, *J. Phys. Chem. A*, 2008, 112, 7652–7661.
- 62 K. Wiberg, *Tetrahedron*, 1968, 24, 1093–1096.
- 63 W. J. Hehre, L. Radom, P. v. R. Schleyer and J. A. Pople, *Abinitio molecular orbital theory*, Wiley, New York, 1986.
- 64 G. Das, *J. Mol. Model.*, 2013, 19, 2981–2991.
- 65 S. Y. Lee and B. H. Boo, *J. Phys. Chem.*, 1996, 100, 8782–8785.
- 66 K. Yokota, M. Hagimori, N. Mizuyama, Y. Nishimura, H. Fujito, Y. Shigemitsu and Y.

Tominaga, *Beilstein J. Org. Chem.*, 2012, 8, 266–274.

- 67 Abdel-Aal, S.E., Gad, Y., Dessouki, A.M., 2006. The use of wood pulp and radiation modified starch in wastewater treatment. *Journal of Applied Polymer Science* 99, 2460–2469.
- 68 Abollino, O., Aceto, M., Malandrino, M., Sarzanini, C., Mentasti, E., 2003. Adsorption of heavy metals on Na-montmorillonite: effect of pH and organic substances. *Water Research* 37 (7), 1619–1627.
69. Aderhold, D., Williams, C.J., Edyvean, R.G.J., 1996. The removal of heavy-metal ions by seaweeds and their derivatives. *Bioresource Technology* 58 (1), 1–6.
70. Ajmal, M., Rao, R.A.K., Ahmad, R., Ahmad, J., 2000. Adsorption studies on *Citrus reticulata* (fruit peel of orange): removal and recovery of Ni(II) from electroplating wastewater. *Journal of Hazardous Materials* 79 (1–2), 117–131.
71. Altin, O., Ozbelge, H.O., Dogu, T., 1998. Use of general purpose adsorption isotherms for heavy metal–clay mineral interactions. *Journal of Colloid Interface Science* 198, 130–140.
72. Alloway, B.J., Ayres, D.C., 1993. *Chemical Principles of Environmental Pollution*, First ed. Chapman & Hall, London, pp. 190–216 .
73. Alvarez-Ayuso, E., Garcia-Sanchez, A., Querol, X., 2003. Purification of metal electroplating waste waters using zeolites. *Water Research* 37 (20), 4855–4862.
74. Andini, S., Cioffi, R., Montagnaro, F., Pisciotta, F., Santoro, L., 2006. Simultaneous adsorption of chlorophenol and heavy metal ions on organophilic bentonite. *Applied Clay Science* 31 (1–2), 126–133.

75. Aoki, N., Fukushima, K., Kurakata, H., Sakamoto, M., Furuhashi, K., 1999a. 6-Deoxy-6-mercaptopropylcellulose and its S-substituted derivatives as sorbents for metal ions. *Reactive and Functional Polymers* 42 (3), 223–233.
76. Aoki, Y., Tanaka, K., Sakamoto, M., Furuhashi, K., 1999b. Sorption of metal ions by bead cellulose grafted with amidoximated polyacrylonitrile. *Sen'i Gakkaishi* 55 (12), 569–575 .
77. Aswathanarayana, U., 2003. *Mineral Resources Management and the Environment*. Routledge, Netherlands, pp. 223–256.
78. Babich, H., Devanas, M.A., Stotzky, G., 1985. The mediation of mutagenicity and clastogenicity of heavy metals by physicochemical factors. *Environmental Research* 37 (2), 253–286.
79. Bao-Xiu, Z., Peng, W., Tong, Z., Chun-yun, C., Jing, S., 2006. Preparation and adsorption performance of a cellulosic adsorbent resin for copper(II). *Journal of Applied Polymer Science* 99, 2951–2956.
80. Barnes, G.L., Davis, A.P., 1996. Dissolution of lead paint in aqueous solution. *Journal of Environmental Engineering ASCE* 122, 663–666.
- 81 . Bayramoglu, G., Bektas, S., Arica, M.Y., 2003. Biosorption of heavy metal ions on immobilized white-rot fungus *Trametes versicolor*. *Journal of Hazardous Materials* 101 (3), 285–300.
82. Benke, N., Takács, E., Wojnárovits, L., Borsa, J., 2007. Pre-irradiation grafting of cellulose and slightly carboxymethylated cellulose (CMC) fibres. *Radiation Physics and Chemistry* 76 (8–9), 1355–1359.
83. Berber-Mendoza, M.S., Leyva-Ramos, R., Alonso-Davila, P., Mendoza-Barron, J., Diaz-Flores, P.E., 2006. Effect of pH and temperature on the ion-exchange isotherm of Cd(II) and

Pb(II) on clinoptilolite. *Journal of Chemical Technology and Biotechnology* 301, 40–45.

84. Bhattacharya, A., Misra, B.N., 2004. Grafting: a versatile means to modify polymers: techniques, factors and applications. *Progress in Polymer Science* 29 (8), 767–814.
85. Bhattacharya, A., 2000. Radiation and industrial polymers. *Progress in Polymer Science* 25 (3), 371–401.
86. Bicak, N., Sherrington, D.C., Senkal, B.F., 1999. Graft copolymer of acrylamide onto cellulose as mercury selective sorbent. *Reactive and Functional Polymers* 41, 69–76.
87. Bicak, N., Senkel, S.F., 1998. Sorbitol-modified poly(*N*-glycidyl styrene sulfonamide) for removal of boron. *Journal of Applied Polymer Science* 68, 2113–2119.
88. Brown, P., Atly Jefcoat, I., Parrish, D., Gill, S., Graham, E., 2000. Evaluation of the adsorptive capacity of peanut hull pellets for heavy metals in solution. *Advances in Environmental Research* 4 (1), 19–29.
89. Castelblanque, J., Salimbeni, F., 2004. NF and RO membranes for the recovery and reuse of water and concentrated metallic salts from waste water produced in the electroplating process. *Desalination* 167, 65–73.
90. Cheng, S.P., 2003. Heavy metal pollution in China: origin, pattern and control. *Environmental Science and Pollution Research* 10 (3), 192–198.
91. Cheung, Y.H., Wong, M.H., 1983. Utilisation of animal manures and sewage sludges for growing vegetables. *Agricultural Wastes* 5 (2), 63–81.

92. Cochrane, E.L., Lu, S., Gibb, S.W., Villaescusa, I., 2006. A comparison of low cost biosorbents and commercial sorbents for the removal of copper from aqueous media. *Journal of Hazardous Materials* 137 (1), 198–206.
93. Crini, G., 2005. Recent developments in polysaccharide-based materials used as adsorbents in wastewater treatment. *Progress in Polymer Science* 30 (1), 38–70.
94. Dal Bosco, S.M., Jimenez, R.S., Carvalho, W.A., 2005. Removal of toxic metals from wastewater by Brazilian natural scolecite. *Journal of Colloid and Interface Science* 281 (2), 424–431.
95. Davis, A.P., Burns, M., 1999. Evaluation of lead concentration in runoff from painted structures. *Water Research* 33 (13), 2949–2958 .
96. Demirbas, E., Kobya, M., Oncel, S., Sencan, S., 2002. Removal of Ni(II) from aqueous solution by adsorption onto hazelnut shell activated carbon: equilibrium studies. *Bioresource Technology* 84 (3), 291–293.
97. Dilek, F.B., Erbay, A., Yetis, U., 2002. Ni(II) biosorption by polyporous versicolor. *Process Biochemistry* 37 (7), 723–726.
98. Dimitrova, S.V., 1996. Metal sorption on blast-furnace slag. *Water Research* 30 (1), 228–232.
99. Feng, D., van Deventer, J.S.J., Aldrich, C., 2004. Removal of pollutants from acid mine wastewater using metallurgical by-product slags. *Separation and Purification Technology* 40 (1), 61–67.
100. Fernandez, Y., Maranon, E., Castrillon, L., Vazquez, I., 2005. Removal of Cd and Zn from inorganic industrial waste leachate by ion exchange. *Journal of Hazardous Materials* 126 (1–3), 169–175.

101. Freundlich, H., 1926. Adsorption. *Journal of Physical Chemistry* 7, 57–64.
102. Friberg, L.I., 1985. Rationale of biological monitoring of chemicals –with special reference to metals. *American Industrial Hygiene Association Journal* 46 (11), 633–642.
103. Gaballah, I., Kilbertus, G., 1998. Recovery of heavy metal ions through decontamination of synthetic solutions and industrial effluents using modified barks. *Journal of Geochemical Exploration* 62 (1–3), 241–286.
104. Gaey, M., Marchetti, V., Clement, A., Loubinoux, B., Gerardin, P., 2000. Decontamination of synthetic solutions containing heavy metals using chemically modified sawdusts bearing polyacrylic acid chains. *Journal of Wood Science* 46, 331–333.
105. Guclu, G., Gurdag, G., Ozgumus, S., 2003. Competitive removal of heavy metal ions by cellulose graft copolymers. *Journal of Applied Polymer Science* 90, 2034–2039 .
106. Guibal, E., 2004. Interactions of metal ions with chitosan-based sorbents: a review. *Separation and Purification Technology* 38 (1), 43–74.
107. Gupta, K.C., Khandehar, K., 2002. Graft copolymerisation of acrylamide–methylacrylate comonomers onto cellulose using ceric ammonium nitrate. *Journal of Applied Polymer Science* 86, 2631–2642.
108. Gurdag, G., Yasar, M., Gurkaynak, M.A., 1997. Graft copolymerisation of acrylic acid on cellulose. *Journal of Applied Polymer Science* 66, 929–934.
109. Hancock, R.D., Martell, A.E., 1989. Ligand design for selective complexation of metal ions in aqueous solution. *Chemical Reviews* 89, 1875– 1914.
110. Harris, J.A., Arthur, J.C., Carra, J.H., 1978. Photoinitiated polymerisation of glycidyl methacrylate with cotton cellulose. *Journal of Applied Polymer Science* 22, 905–915.

111. Hashem, A., 2006. Amidoximated sunflower stalks (ASFS) as a new adsorbent for removal of Cu(II) from aqueous solution. *Polymer– Plastics Technology and Engineering* 45, 35–42.
112. Hilal, N., Al-Khatib, L., Atkin, B.P., Kochkodan, V., Potapchenko, N., 2003. Photochemical modification of membrane surfaces for (bio)fouling reduction: a nano-scale study using AFM. *Desalination and the Environment: Fresh Water for All* 158 (1–3), 65–72.
113. Hon, D.N.S., 1982. Graft Copolymerization of Lignocellulosic Fibers. American Chemical Society Symposium Series, 187, Washington DC, USA.
114. IARC, 1990. Monograph on the Evaluation of Carcinogenic Risk to Humans, vol. 49, Chromium, Nickel and Welding. International Agency for Research on Cancer, Lyon.
115. Kamel, S., Hassan, E.M., El-Sakhawy, M., 2006. Preparation and application of acrylonitrile-grafted cyanoethyl cellulose for the removal of copper(II) ions. *Journal of Applied Polymer Science* 100, 329–334.
116. Langmuir, I., 1918. The adsorption of gases on plane surfaces of glass, mica and platinum. *Journal of the American Chemical Society* 40 (9), 1361–1402.
117. Lee, S.T., Mi, F.L., Shen, Y.J., Shyu, S.S., 2001. Equilibrium and kinetics studies of copper(II) ion uptake by chitosan-tripolyphosphate chelating resin. *Polymer* 42, 1879–1892 .
118. Theophanides, T., Anastassopoulou, J., 2002. Copper and carcinogenesis, critical reviews. *Oncology/Haematology* 42 (1), 57–64.
119. US Geological Survey, 2004. Minerals commodity summaries. Available from: <<http://minerals.usgs.gov/minerals/pubs/commodity>>.

120. Vaughan, T., Seo, C.W., Marshall, W.E., 2001. Removal of selected metal ions from aqueous solution using modified corncobs. *Bioresource Technology* 78 (2), 133–139.
121. Veglio, F., Quaresima, R., Fornari, P., Ubaldini, S., 2003. Recovery of valuable metals from electronic and galvanic industrial wastes by leaching and electrowinning. *Waste Management* 23 (3), 245–252.
122. Villaescusa, I., Fiol, N., Martinez, M., Miralles, N., Poch, J., Serarols, J., 2004. Removal of copper and nickel ions from aqueous solutions by grape stalk wastes. *Water Research* 38 (4), 992–1002.
123. Walter, I., Martinez, F., Cala, V., 2006. Heavy metal speciation and phytotoxic effects of three representative sewage sludges for agricultural uses. *Environmental Pollution* 139 (3), 507–514.
124. Wang, L.K., Hung, N.K., Shammass, N.K., 2004. *Physiochemical Treatment Processes*, vol. 3. Human Press, New Jersey, pp. 103–138.
125. Wang, Y.H., Lin, S.H., Juang, R.S., 2003. Removal of heavy metal ions from aqueous solutions using various low-cost adsorbents. *Journal of Hazardous Materials* 102 (2–3), 291–302.
126. Waste Strategy, 2004. New energy goes into battery recycling. In: *Environment for Europeans – Magazine of the E.U. Directorate General of the Environment*.
127. Weiss, B., Landrigan, P.J., 2000. The developing brain and the environment: an introduction. *Environmental Health Perspectives* 108, 373–374.
128. Yavuz, O., Altunkaynak, Y., Guzel, F., 2003. Removal of copper, nickel, cobalt and manganese from aqueous solution by kaolinite. *Water Research* 37 (4), 948–952.

129. Zhao, M., Duncan, J.R., van Hille, R.P., 1999. Removal and recovery of zinc from solution and electroplating effluent using *Azolla filiculoides*. *Water Research* 33 (6), 1516–1522.
130. Zhou, D., Zhang, L., Zhou, J., Guo, S., 2004. Cellulose/Chitin beads for adsorption of heavy metals in aqueous solution. *Water Research* 38, 2643–2650.

MART SPECIALITIES LAB LLP.

Operator Name: Jyothi

Report Date: 11-06-2022 17:40:20

Results File: E:\AAS System Data\2022\JUNE\11 06 2022\TARA 0064 2-6\Iron (Fe)1.SLR

General Parameters

Method : Iron (Fe)

Operator : Jyothi

Instrument Mode: Flame

Autosampler : None

Dilution: None

Use SFI: No

Valid Method Signatures

11-06-2022 17:22:33 jyothi(M. Jyothi):DESKTOP-39TDEGC

Signed with Reason : Analysed by:

11-06-2022 17:23:24 parjanya(Parjanya):DESKTOP-39TDEGC

Signed with Reason : Approved by:

Method Audit Trail

11-06-2022 17:22:18 Jyothi(M. Jyothi):DESKTOP-39TDEGC

Record created

11-06-2022 17:22:33 jyothi(M. Jyothi):DESKTOP-39TDEGC

Signed with Reason : Analysed by:

11-06-2022 17:23:24 parjanya(Parjanya):DESKTOP-39TDEGC

Signed with Reason : Approved by:

Analysis Details

Analysis Name: Iron (Fe) 11-06-2022

Spectrometer: ICE 3000 AA01204906 v1.30

Operator Name: Jyothi

Lamp Information

Element(s)	Serial Number	mA Hours
Fe	n/a	n/a

Deuterium Lamp Hours: 68.34

Sequence Table

Shared Standards: Yes

Action	Fe
Calibration	✓
B.No.Group-II	✓
B.No.Group-III	✓
B.No.Group-IV	✓
B.No.Group-V	✓
B.No.Group-VI	✓

Sample Details

No.	Sample Id	Nominal Mass: 1.0000 Sample Mass	Dilution Ratio
1	B.No.Group-II	1.0000	1.0000
2	B.No.Group-III	1.0000	1.0000
3	B.No.Group-IV	1.0000	1.0000
4	B.No.Group-V	1.0000	1.0000
5	B.No.Group-VI	1.0000	1.0000

Valid Analysis Signatures

11-06-2022 17:38:41 jyothi(M. Jyothi):DESKTOP-39TDEGC

Signed with Reason : Analysed by:

11-06-2022 17:39:33 parjanya(Parjanya):DESKTOP-39TDEGC

Signed with Reason : Approved by:

Analysis Audit Trail

11-06-2022 17:30:16 Jyothi(M. Jyothi):DESKTOP-39TDEGC

Record created

11-06-2022 17:38:27 Jyothi(M. Jyothi):DESKTOP-39TDEGC

Error MD147 - Activity manually aborted by user.

11-06-2022 17:38:41 jyothi(M. Jyothi):DESKTOP-39TDEGC

Signed with Reason : Analysed by:

11-06-2022 17:39:33 parjanya(Parjanya):DESKTOP-39TDEGC

Signed with Reason : Approved by:

MART SPECIALITIES LAB LLP.

Operator Name: Jyothi

Report Date: 11-06-2022 17:40:20

Results File: E:\AAS System Data\2022\JUNE\11 06 2022\TARA 0064 2-6\Iron (Fe)1.SLR

Spectrometer Parameters - Fe

Element: Fe

Measurement Mode: Absorbance

Wavelength: 248.3nm

Bandpass: 0.2nm

Lamp Current: 75%

Background Correction: D2

High Resolution: Off

Optimise Spectrometer Parameters: No

Signal Type: Continuous

Resamples: Fast

Number Of Resamples: 3

Measurement Time: 4.0secs

Flier Mode: No

Use RSD Test: No

Flame Parameters - Fe

Flame Type: Air-C2H2

Fuel Flow: 0.9L/min

Auxiliary Oxidant: Off

Nebuliser Uptake: 4secs

Burner Stabilisation: 0mins

Optimise Fuel Flow: No

Burner Height: 7.0mm

Optimise Burner Height: No

Sampling Parameters - Fe

Sampling: None

Calibration Parameters - Fe

Calibration Mode: Normal

Line Fit: Linear

Use Stored Calibration: No

Concentration Units: mg/L

Scaled Units: mg/L

Scaling Factor: 1.0000

Acceptable Fit: 0.990

Rescale Limit: 10.0%

Failure Action: Flag and Continue

Standard 1	2.0000
Standard 2	4.0000
Standard 3	6.0000

Standard 4	8.0000
Standard 5	10.0000

Element Audit Trail - Fe

No changes are recorded for this element

Solution Results - Fe

$$Y = 0.04924x + 0.0141$$

Fit: 0.9965

Characteristic Conc: 0.0894

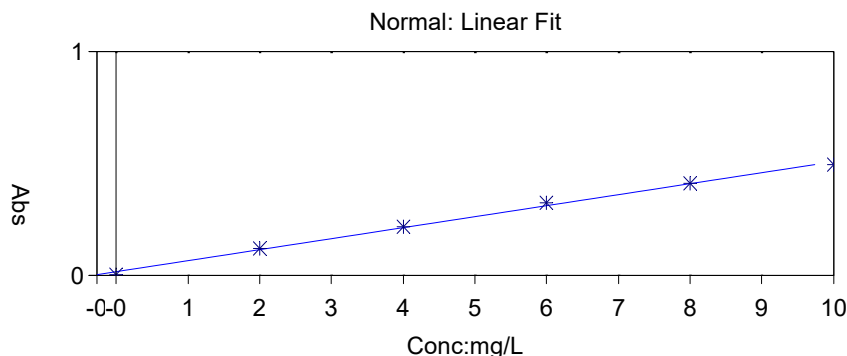

Sample ID	Signal	Rsd	Conc	Corrected Conc
	Abs	%	mg/L	mg/L
Fe Blank	0.001	35.6	0.0000	
1	0.001	Background: -0.003		11-06-2022 17:31:26
2	0.001	Background: -0.003		11-06-2022 17:31:30
3	0.000	Background: -0.003		11-06-2022 17:31:35
Fe Standard 1	0.120	0.3	2.0000	
1	0.120	Background: 0.003		11-06-2022 17:32:05
2	0.119	Background: 0.003		11-06-2022 17:32:09
3	0.120	Background: 0.003		11-06-2022 17:32:13
Fe Standard 2	0.215	0.3	4.0000	
1	0.215	Background: 0.004		11-06-2022 17:32:40
2	0.215	Background: 0.004		11-06-2022 17:32:45
3	0.216	Background: 0.004		11-06-2022 17:32:49
Fe Standard 3	0.322	0.2	6.0000	
1	0.323	Background: 0.005		11-06-2022 17:33:19
2	0.322	Background: 0.005		11-06-2022 17:33:23
3	0.322	Background: 0.005		11-06-2022 17:33:27
Fe Standard 4	0.411	0.3	8.0000	
1	0.410	Background: 0.005		11-06-2022 17:33:59
2	0.412	Background: 0.005		11-06-2022 17:34:03
3	0.412	Background: 0.005		11-06-2022 17:34:07

MART SPECIALITIES LAB LLP.

Operator Name: Jyothi

Report Date: 11-06-2022 17:40:20

Results File: E:\AAS System Data\2022\JUNE\11 06 2022\TARA 0064 2-6\Iron (Fe)1.SLR

Solution Results - Fe

Sample ID	Signal	Rsd	Conc	Corrected Conc
	Abs	%	mg/L	mg/L
Fe Standard 5	0.493	0.1	10.0000	
1	0.494	Background: 0.005		11-06-2022 17:34:38
2	0.494	Background: 0.005		11-06-2022 17:34:42
3	0.493	Background: 0.006		11-06-2022 17:34:46
Fe B.No.Group-II	0.834	0.1	16.6490 C	16.6490 C
1	0.834	Background: 0.005		11-06-2022 17:35:14
2	0.833	Background: 0.005		11-06-2022 17:35:19
3	0.834	Background: 0.005		11-06-2022 17:35:23
Fe B.No.Group-III	0.759	0.1	15.1286 C	15.1286 C
1	0.758	Background: 0.003		11-06-2022 17:35:52
2	0.760	Background: 0.003		11-06-2022 17:35:56
3	0.758	Background: 0.004		11-06-2022 17:36:00
Fe B.No.Group-IV	0.645	0.3	12.8189 C	12.8189 C
1	0.647	Background: 0.003		11-06-2022 17:36:31
2	0.644	Background: 0.003		11-06-2022 17:36:35
3	0.645	Background: 0.003		11-06-2022 17:36:40
Fe B.No.Group-V	0.809	0.2	16.1488 C	16.1488 C
1	0.808	Background: 0.005		11-06-2022 17:37:11
2	0.809	Background: 0.005		11-06-2022 17:37:15
3	0.811	Background: 0.005		11-06-2022 17:37:20
Fe B.No.Group-VI	0.711	0.3	14.1597 C	14.1597 C
1	0.709	Background: 0.005		11-06-2022 17:37:55
2	0.713	Background: 0.005		11-06-2022 17:37:59
3	0.712	Background: 0.004		11-06-2022 17:38:03

MART Specialities Lab. LLP

Work : Road No. : 03, Plot No.: 31, Ground Floor & 1st Floor, Gajularamaram, ALEAP Industrial Area,
Pragathi Nagar, Medhcal, Medchal-Malkajgiri - 500 055, Telangana, India,
Tel. : 85007 98350, 81423 98350 & 98481 98350 Mail:martspecialities@gmail.com



DCA Approval No: 05/ML/TS/2020/G

CERTIFICATE OF ANALYSIS

MSL/QA/017-03/F07-00

Name & Address of the Customer: Tara Government College Prashanth Nagar Colony, Balajinagar Sangareddy Telangana. 502000 Contact Person: Dr. Abhijeet Contact Number :9502344392	Reference / Report No. : MSL/2022/JUNE/TARA/0064-1 Sample Received Date : 11/06/2022 Report Date : 13/06/2022
---	--

DETAILS OF THE SAMPLE

Sample Name : NA
Name of the Manufacturer : NA
Batch no : Group-I Mfg. : NA Exp. : NA
Storage condition : To be stored at room date date
Temperature : 25°C±3°C Batch : NA
Room Temperature : 25°C±3°C size
Quantity Received : 4gm
Tests Required : Iron by AAS Analysis.
Method : NA
Analysis Starting Date : 11/06/2022
Analysis Completion Date : 11/06/2022
Mfg. License No. : Not provided
A.R.NO : NA
Remark : Sample analyzed as received

Test Results

S.No.	Test Parameter	Result
01.	Iron by AAS Analysis: (ppm)	620ppm

Authorized Signatory

(Dr.R.Marayya)

MART Specialities Lab. LLP

Work : Road No. : 03, Plot No.: 31, Ground Floor & 1st Floor, Gajularamaram, ALEAP Industrial Area, Pragathi Nagar, Medhcal, Medchal-Malkajgiri - 500 055, Telangana, India,
Tel. : 85007 98350, 81423 98350 & 98481 98350 Mail:martspecialities@gmail.com



DCA Approval No: 05/ML/TS/2020/G

CERTIFICATE OF ANALYSIS

MSL/QA/017-03/F07-00

Name & Address of the Customer:

Tara Government College
Prashanth Nagar Colony, Balajinagar
Sangareddy Telangana. 502000
Contact Person: Dr. Abhijeet
Contact Number :9502344392

Reference / Report No. : MSL/2022/JUNE/TARA/0064-2
Sample Received Date : 11/06/2022
Report Date : 13/06/2022

DETAILS OF THE SAMPLE

Sample Name : NA
Name of the Manufacturer : NA
Batch no : Group-II Mfg. : NA Exp. : NA
Storage condition : To be stored at room date date
Room Temperature : 25°C±3°C Temperature Batch : NA
Quantity Received : 4gm size
Tests Required : Iron by AAS Analysis.
Method : NA
Analysis Starting Date : 11/06/2022
Analysis Completion Date : 11/06/2022
Mfg. License No. : Not provided
A.R.NO : NA
Remark : Sample analyzed as received

Test Results

S.No.	Test Parameter	Result
01.	Iron by AAS Analysis: (ppm)	832.5ppm

Authorized Signatory

(Dr.R.Marayya)

MART Specialities Lab. LLP

Work : Road No. : 03, Plot No.: 31, Ground Floor & 1st Floor, Gajularamaram, ALEAP Industrial Area,
Pragathi Nagar, Medhcal, Medchal-Malkajgiri - 500 055, Telangana, India,
Tel. : 85007 98350, 81423 98350 & 98481 98350 Mail:martspecialities@gmail.com



DCA Approval No: 05/ML/TS/2020/G

CERTIFICATE OF ANALYSIS

MSL/QA/017-03/F07-00

Name & Address of the Customer: Tara Government College Prashanth Nagar Colony, Balajinagar Sangareddy Telangana. 502000 Contact Person: Dr. Abhijeet Contact Number :9502344392	Reference / Report No. : MSL/2022/JUNE/TARA/0064-3 Sample Received Date : 11/06/2022 Report Date : 13/06/2022
---	---

DETAILS OF THE SAMPLE

Sample Name	: NA	Mfg.	: NA	Exp.	: NA
Name of the Manufacturer	: NA	date		date	
Batch no	: Group-III	Batch		Batch	: NA
Storage condition	: To be stored at room	size		size	
Room Temperature	: 25°C±3°C				
Quantity Received	: 4gm				
Tests Required	: Iron by AAS Analysis.				
Method	: NA				
Analysis Starting Date	: 11/06/2022				
Analysis Completion Date	: 11/06/2022				
Mfg. License No.	: Not provided				
A.R.NO	: NA				
Remark	: Sample analyzed as received				

Test Results

S.No.	Test Parameter	Result
01.	Iron by AAS Analysis: (ppm)	756.5ppm

Authorized Signatory

(Dr.R.Marayya)

MART Specialities Lab. LLP

Work : Road No. : 03, Plot No.: 31, Ground Floor & 1st Floor, Gajularamaram, ALEAP Industrial Area, Pragathi Nagar, Medhcal, Medchal-Malkajgiri - 500 055, Telangana, India,
Tel. : 85007 98350, 81423 98350 & 98481 98350 Mail:martspecialities@gmail.com



DCA Approval No: 05/ML/TS/2020/G

CERTIFICATE OF ANALYSIS

MSL/QA/017-03/F07-00

Name & Address of the Customer: Tara Government College Prashanth Nagar Colony, Balajinagar Sangareddy Telangana. 502000 Contact Person: Dr. Abhijeet Contact Number :9502344392	Reference / Report No. : MSL/2022/JUNE/TARA/0064-4 Sample Received Date : 11/06/2022 Report Date : 13/06/2022
---	--

DETAILS OF THE SAMPLE

Sample Name	: NA				
Name of the Manufacturer	: NA				
Batch no	: Group-IV	Mfg. date	: NA	Exp. date	: NA
Storage condition	: To be stored at room Temperature			Batch size	: NA
Room Temperature	: 25°C±3°C				
Quantity Received	: 4gm				
Tests Required	: Iron by AAS Analysis.				
Method	: NA				
Analysis Starting Date	: 11/06/2022				
Analysis Completion Date	: 11/06/2022				
Mfg. License No.	: Not provided				
A.R.NO	: NA				
Remark	: Sample analyzed as received				

Test Results

S.No.	Test Parameter	Result
01.	Iron by AAS Analysis: (ppm)	641ppm

Authorized Signatory

(Dr.R.Marayya)

MART Specialities Lab. LLP

Work : Road No. : 03, Plot No.: 31, Ground Floor & 1st Floor, Gajularamaram, ALEAP Industrial Area,
Pragathi Nagar, Medchal, Medchal-Malkajgiri - 500 055, Telangana, India,
Tel. : 85007 98350, 81423 98350 & 98481 98350 Mail:martspecialities@gmail.com



DCA Approval No: 05/ML/TS/2020/G

CERTIFICATE OF ANALYSIS

MSL/QA/017-03/F07-00

Name & Address of the Customer: Tara Government College Prashanth Nagar Colony, Balajinagar Sangareddy Telangana. 502000 Contact Person: Dr. Abhijeet Contact Number :9502344392	Reference / Report No. : MSL/2022/JUNE/TARA/0064-5 Sample Received Date : 11/06/2022 Report Date : 13/06/2022
DETAILS OF THE SAMPLE	
Sample Name : NA	
Name of the Manufacturer : NA	
Batch no : Group-V	Mfg. : NA Exp. : NA
Storage condition : To be stored at room	date : NA
Room Temperature : 25°C±3°C	Batch : NA
Quantity Received : 4gm	size
Tests Required : Iron by AAS Analysis.	
Method : NA	
Analysis Starting Date : 11/06/2022	
Analysis Completion Date : 11/06/2022	
Mfg. License No. : Not provided	
A.R.NO : NA	
Remark : Sample analyzed as received	

Test Results

S.No.	Test Parameter	Result
01.	Iron by AAS Analysis: (ppm)	807.5ppm

Authorized Signatory

(Dr.R.Marayya)

MART Specialities Lab. LLP

Work : Road No. : 03, Plot No.: 31, Ground Floor & 1st Floor, Gajularamaram, ALEAP Industrial Area,
Pragathi Nagar, Medhcal, Medchal-Malkajgiri - 500 055, Telangana, India,
Tel. : 85007 98350, 81423 98350 & 98481 98350 Mail:martspecialities@gmail.com



DCA Approval No: 05/ML/TS/2020/G

CERTIFICATE OF ANALYSIS

MSL/QA/017-03/F07-00

Name & Address of the Customer: Tara Government College Prashanth Nagar Colony, Balajinagar Sangareddy Telangana. 502000 Contact Person: Dr. Abhijeet Contact Number :9502344392	Reference / Report No. : MSL/2022/JUNE/TARA/0064-6 Sample Received Date : 11/06/2022 Report Date : 13/06/2022
---	---

DETAILS OF THE SAMPLE

Sample Name	: NA				
Name of the Manufacturer	: NA				
Batch no	: Group-VI	Mfg. date	: NA	Exp. date	: NA
Storage condition	: To be stored at room Temperature			Batch size	: NA
Room Temperature	: 25°C±3°C				
Quantity Received	: 4gm				
Tests Required	: Iron by AAS Analysis.				
Method	: NA				
Analysis Starting Date	: 11/06/2022				
Analysis Completion Date	: 11/06/2022				
Mfg. License No.	: Not provided				
A.R.NO	: NA				
Remark	: Sample analyzed as received				

Test Results

S.No.	Test Parameter	Result
01.	Iron by AAS Analysis: (ppm)	708ppm

Authorized Signatory

(Dr.R.Marayya)