

**ADSORPTION STUDIES OF Fe[III] ON
BENTONITE IN THE PRESENCE OF D-RIBOSE
AS CHELATING AGENT**

*Dissertation submitted in Partial fulfillment for the requirements for the award of
degree of*

*Bachelor of Science
in
CHEMISTRY*

By

- | | |
|---------------------|----------------------------|
| 1. T. Chandana, | B.Sc (Chemistry), III Year |
| 2. T. Pranay kumar, | B.Sc (Chemistry), III Year |
| 3. T. Shiva charan, | B.Sc (Chemistry), III Year |
| 4. N. Sai mahesh, | B.Sc (Chemistry), III Year |
| 5. T. Raghavendra, | B.Sc (Chemistry), III Year |

Under the Guidance:

K.SREEDHAR
Assistant Professor
DEPARTMENT OF CHEMISTRY



Tara Government College, Sangareddy(A)
2021-22

CERTIFICATE

This is to certify that the project work entitled “ADSORPTION STUDIES OF Fe[III] ON BENTONITE IN THE PRESENCE OF D-RIBOSE AS CHELATING AGENT” is presented by B.Sc (CHEMISTRY) students in partial fulfillment of the requirements for the degree of Bachelor of Science in Chemistry by the Tara Govt. College, Sangareddy(A) (Affiliated to Osmania University, Hyderabad) during the academic year 2021-2022.

The results embodied in this report have not been to any other University or Institution for the award of any degree.

(K.SREEDHAR)

**Asst. Professor, Department of Chemistry
Tara Government College, Sangareddy (A)**

EXTERNAL EVALUATOR

ACKNOWLEDGEMENTS

*We express my deep gratitude to my research supervisor **K.Sreedhar**, Asst. Professor, Department of Chemistry, Tara Govt. College, Sangareddy(A)-502001, INDIA for his inspiring guidance during the course of the Project work. The continuous encouragement extended by him propelled me to update my research skills and pedigree to engage in fruitful research.*

*We wish to express our gratitude to **Smt. M.Praveena**, Principal, Tara Govt. College, Sangareddy(A)-502001, INDIA for her constant support, cooperation and suggestions during the research work. We wish to express our sincere thanks to **Dr.K.Abhijit**, Head, Department of Chemistry, Tara Govt. College, Sangareddy(A)-502001, INDIA for providing me facilities, help and support for the entire research work.*

*We express our special thanks to **MART Specialities Lab, Hyderabad** for providing technical assistance in Atomic absorption spectrometric analysis.*

Finally, we take this opportunity to thank one and all that has directly or indirectly helped me in completing the task.

- | | |
|----------------------------|------------------------------------|
| 1. T. Chandana, | B.Sc (Chemistry) , III Year |
| 2. T. Pranay kumar, | B.Sc (Chemistry) , III Year |
| 3. T. Shiva charan, | B.Sc (Chemistry) , III Year |
| 4. N. Sai mahesh, | B.Sc (Chemistry) , III Year |
| 5. T. Raghavendra, | B.Sc (Chemistry) , III Year |

DECLARATION

*We hereby declare that the project report entitled “**ADSORPTION STUDIES OF Fe[III] ON BENTONITE IN THE PRESENCE OF D-RIBOSE AS CHELATING AGENT**” is the work done by us in the campus at **Department of Chemistry, Tara Government College, Sangareddy(A)** during the academic year 2021-2022 and is submitted in partial fulfillment of the requirements for the degree of **Bachelor of Science** by **Tara Govt. College, Sangareddy(A)** (Affiliated to **Osmania University, Hyderabad**) during the academic year 2021-2022.*

S.No.	Name of the Student	Roll Number	Group	Year	Signature
1	T.CHANDANA	6058-19-578-032	B.Sc(MCCs)	III	
2	T.PRANAY KUMAR	6058-19-578-033	B.Sc(MCCs)	III	
3	T.SHIVA CHARAN	6058-19-578-034	B.Sc(MCCs)	III	
4	N.SAI MAHESH	6058-19-578-026	B.Sc(MCCs)	III	
5	T.RAGHAVENDRA	6058-19-578-035	B.Sc(MCCs)	III	

**TARA GOVERNMENT COLLEGE, SANGAREDDY – 502 001
(AUTONOMOUS)**

BONAFIDE CERTIFICATE

*Certified that the project report " ADSORPTION STUDIES OF Fe[III]
ON BENTONITE IN THE PRESENCE OF D-RIBOSE AS CHELATING
AGENT" is the bonafide work of*

- | | |
|---------------------|-----------------------------|
| 1. T. Chandana, | B.Sc (Chemistry) , III Year |
| 2. T. Pranay kumar, | B.Sc (Chemistry) , III Year |
| 3. T. Shiva charan, | B.Sc (Chemistry) , III Year |
| 4. N. Sai mahesh, | B.Sc (Chemistry) , III Year |
| 5. T. Raghavendra, | B.Sc (Chemistry) , III Year |

who carried out the project work under my supervision.

K.Sreedhar
PROJECT SUPERVISOR

Dr.K.ABHIJIT
HEAD, DEPARTMENT OF CHEMISTRY

Smt. M.PRAVEENA
PRINCIPAL

CONTENTS

S.No.	CHAPTERS	Pg.No.
1	INTRODUCTION	1-5
2	ADSORPTION OF SOLUTES FROM DILUTE SOLUTIONS	6-10
3	ATOMIC ABSORPTION SPECTROMETRY	11-18
4	METHODOLOGY	19-29
5	RESULTS AND DISCUSSION	30-38

Chapter-I

INTRODUCTION

ADSORPTION

Adsorption is a process in which solids come into contact with liquids or gases, and the mass transfer occurs from liquids to solids. Desorption is the reversal of this action. Adsorption operations take advantage of a solid's capacity to concentrate certain chemicals from a fluid on to its surface. Adsorbate refers to the adsorbed substance, while adsorbent refers to the solid substance. The following are some examples of solid-liquid and solid-gas applications:

- Removing dissolved moisture from gasoline.
- Decolorization of sugar solutions and petroleum products.
- Removing noxious odors and tastes from water. Dehumidification of air and gases is one of the solid-gas activities.
- To fractionate mixtures of hydrocarbon gases such as methane, ethane, and propane.
- To remove undesirable odors and contaminants from gases.
- To recover valuable solvent vapors from dilute gas mixtures.

NATURE OF ADSORBENTS

Adsorbents are typically granular in nature, ranging in size from 0.5 mm to 12 mm. They can't have a lot of pressure decrease or get swept away by a fast-moving stream. During handling, they must maintain their shape and size. They'll need a lot of pores and a lot of surface area per unit mass.

Some of the commonly used adsorbents, their sources and applications are given below:

Sl. No.	Adsorbent	Source	Application
1.	Fuller's earth	Naturally occurring clay is heated and dried to get a porous structure.	De-colorizing, drying of lubricating oils, kerosene and engine oils.
2.	Activated charcoal	Bentonite or other activated clay which are activated by treatment with sulfuric acid and further washing, drying and crushing.	Used for de-colorizing petroleum products.
3.	Bauxite	A naturally occurring hydrated alumina, activated by heating at 230-815	Used for de-colorizing petroleum products and for drying gases.

4.	Alumina	A hard hydrated aluminum oxide, which is activated by heating to drive off the moisture and then crushed to desired size.	Used as desiccant.
5.	Bone-char	Obtained by destructive distillation of crushed bones at 600-900	Used for refining sugar and can be reused after washing and burning.
6.	Silica gel	A hard granular and porous product obtained from sodium silicate solution after treatment with acid. Normally has 4 to 7% water in the product.	Dehydration of gases and liquids, and separation of gas-liquid hydrocarbon mixture.

7.	Activated carbon	<p>(1) Vegetable matter is mixed with calcium chloride, carbonized and finally the inorganic compounds are leached away.</p> <p>(2) Organic matter is mixed with porous pumice stones and then heated and carbonized to deposit the carbonaceous matter throughout the porous particle.</p> <p>(3) Carbonizing substances like wood, sawdust, coconut shells, fruit pits, coal, lignite and subsequent activation with hot air steam. It is available in granular or pelleted form.</p>	<p>De-colorizing of sugar solutions, chemicals, drugs, water purification, refining of vegetable and animal oils, recovery of gold and silver from cyanide ore-leach solution, recovery of solvent vapor from gas-mixtures, collection of gasoline hydrocarbons from natural gas, fractionation of hydrocarbon gases.</p>
8.	Molecular sieves	<p>These are porous synthetic zeolite crystals, metal alumino-silicates.</p>	<p>Dehydration of gases and liquids, and separation of gas-liquid hydrocarbon mixture.</p>

SIGNIFICANCE OF RESEARCH PROBLEM

Adsorption of heavy metals is an important strategy to develop newer remediation technologies for the sustainable environmental protection. But the efficacy of adsorption of heavy metals under the normal conditions using suitable adsorbent depends on several factors which need to be finely tuned to get efficient adsorption process. In the presence of proper facilitating agents, the adsorption of heavy metals enhanced which will certainly improves the existing heavy metal techniques.

OBJECTIVE OF THE PROJECT

To evaluate the impact of D-Ribose as a chelating agent in the adsorption of Fe (III) from aqueous solution by Bentonite as an adsorbent to develop efficient remediation technology using concept of Coordination chemistry.

Chapter-II

ADSORPTION OF SOLUTES FROM DILUTE SOLUTIONS

Both the solvent and the solute are adsorbed whenever a mixture of solute and solvent is adsorbed using an adsorbent. As a result, only relative or apparent solute adsorption can be determined. As a result, treating a known volume of solution of original concentration C with a known weight of adsorbent is standard procedure. Let C^* be the solution's final equilibrium solute concentration. If v is the volume of solution per unit mass of adsorbent (cc/g), and C and C^* are the starting and equilibrium concentrations (g/cc) of the solute, then the apparent adsorption of the solute per unit mass of adsorbent is $v(C - C^*)$, (g/g), neglecting any volume change. This statement is most useful in the case of dilute solutions. The C^* value is determined by the temperature, nature, and properties of the adsorbent when the proportion of the original solvent that can be adsorbed is tiny. The Freundlich adsorption isotherm, $C^* = K[v(C - C^*)]^n$, represents the adsorption phenomena in dilute fluids across a small concentration range. The Freundlich adsorption equation is especially useful in situations where the identification of the solute is unknown, such as the removal of coloring substances from sugar solutions, oils, and other liquids. A spectrophotometer or colorimeter can quickly determine the color composition of the solute. In worked example 2, the interpretation of this data is demonstrated. Adsorption is good if the value of n is high, say 2 to 10. If it's between 1 and 2, it's relatively challenging, and if it's less than 1, it's easy and it indicates poor adsorption characteristics. Freundlich adsorption equation is also useful in such a case where the actual identification of solute is not known, e.g., removal of coloring substance from sugar solutions, oils etc. A typical adsorption isothermal for the adsorption of various adsorbents A, B and C in dilute solution at the same temperature for the same adsorbent is represented in a graph.

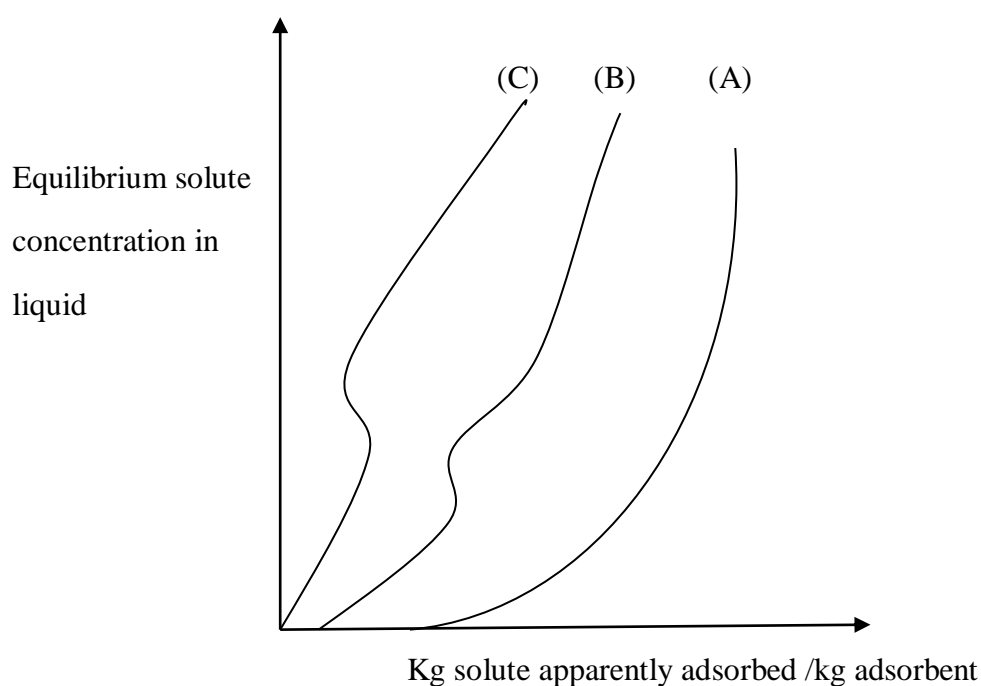

Adsorption isotherms for various adsorbents

METAL COMPLEXATION OF A D- RIBOSE- BASED LIGAND

The complexation characteristics of methyl 2, 3, 4-tri-O-(2-picolyl)—D-ribose, a novel sugar-derived hexadentate ligand, were investigated using a combination of experimental and theoretical approaches. In the complexes with Mn^{II} , Co^{II} , Ni^{II} , and Zn^{II} , the coordination bond lengths reveal significant departures from perfect octahedral, with deformation towards trigonal-prismatic geometries, indicating a conformationally constrained ligand. The metal-cation–ligand interactions for D-Ribose and its acyclic analogue ligand [1, 2, 3-tri-O-(2-picolyl)-1, 2, 3-propanetriol] were investigated using spectroscopic techniques and isothermal calorimetric titrations for the series Mn^{II} , Co^{II} , Ni^{II} , Zn^{II} , and Cu^{II} . Depending on the nature of the metal, the results show that the complexes produced with D-Ribose are more stable than those obtained with According to molecular modelling studies; the presence of the sugar moiety greatly favours conformations that are compatible with metal binding. In many ways, a close comparison can be sketched between metal complexation and other host-guest interactions. To describe them both, several molecular variables have to be taken into consideration. One of the most

complex variables is the relation between the conformational flexibility of the ligand and the binding strength of the metal cation. For ligands with a reduced number of low-energy conformations, relatively straightforward estimations of the binding same wavelength of metal cations as well as a direct interaction between structural and thermodynamic data are available. However, for ligands with a huge number of degrees of freedom, the correct orientation of the chelating groups becomes one of the most important issues in metal-ion identification processes. For coordination chemists, the prediction and understanding about coordination properties of new ligands is one the most challenging tasks. We decided to investigate how entropic and enthalpic variables can impact on metal binding and selectivity for systems with a substantial number of degrees of freedom.

FERRIC COMPLEXES OF SUGAR-TYPE LIGAND

Fe (III) complexes formed with sugar-type ligands such as aldoses, ketoses, polyalcohols, sugar acids, di and trisaccharides was prepared. These complexes composition was determined by standard analytical methods. Deprotonated alcoholic hydroxy groups participate in the complex formation which results in the formation of polynuclear species. Mossbauer spectra reflected the presence of high spin iron (III) central atoms. EPR spectra showed antiferromagnetic interactions between the iron(III) centres in the complexes indicating dimeric or oligomeric complex structures. Depending upon the nature of a ligand as well as on the preparation mode of the complexes the ratio of interacting and isolated iron(III) is calculated. Formation of polynuclear iron(III) complexes of D-fructose, sorbose, lactobionic acid, glucose, galactose, mannose, and lactose were shown by the analysis and structural study by the sugar type ligand with ferric system. Ferric complexes of reducing sugars also contained ferrous species in some cases. The combination of Mossbauer spectroscopic measurements with ERP or magnetic susceptibility studies has led valuable information concerning the intramolecular and electronic structure on which the system has been developed.

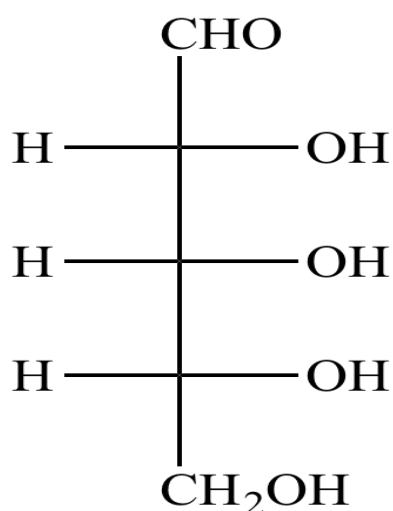

Structure of D-Ribose

BENTONITE AS ADSORBENT

Because of heavy metals toxicity and non-biodegradable nature, the advent of heavy metals in water is turning into a critical environmental and public fitness concern. A variety of technology were evolved to do away with poisonous heavy metals from wastewater. The maximum crucial technology for the heavy steel ions elimination from wastewater consist of perception, ion exchange, adsorption, coagulation, evaporation and opposite osmosis. Adsorption on strong matrices has been proven to be an economically viable opportunity method (Abollino et al., 2003¹; Hoda et al., 2009² Kapoor and Vira Raghavan, 1998³). Cheaper Na-bentonite has been observed to be so beneficial for elimination of heavy steel ions from aqueous answers that it has attracted geologists and environmental engineers (Al-Quadbit et al., 2005⁴; Guo et al.,(2009).

The Na-bentonite from Gaomiaozi has been used as boundaries to save you infection of wastewater containing heavy metals. For this cause it's far crucial to take a look at the adsorption of metals of metals via way of means of Na-bentonite so one can offer crucial parameters and essential principle for the knowledge of adsorptive elimination of heavy metals via way of means of Na-bentonite from an aqueous environment. The bivalence ions of copper and nickel are not unusual

place observed within the commercial wastewater. The bivalence ions of copper and nickel are commonly found in the industrial wastewater. On a Na-montmorillonite turned into studied as feature of answer pH, dosage of Na-bentonite, temperature and make contact with and make contact with time. The aggressive isothermal Adsorption conduct of copper and nickel on Na-bentonite in single-aspect structures and binary-aspect structures has been investigated.



BENTONITE POWDER

Chapter-III

ATOMIC ABSORPTION SPECTROMETRY

Atomic absorption spectrometry (AAS) is an analytical technique that measures the concentrations of elements. Atomic absorption is so sensitive that it can measure down parts per billion of a gram ($\mu\text{g dm}^{-3}$) in a sample. The technique makes use of the wavelengths of light specifically absorbed by an element. They correspond to the energies needed to promote electrons from one energy level to another, higher, energy level.

Atomic absorption spectrometry has many uses in different areas of chemistry.

Clinical analysis: Analysing metals in biological fluids such as blood and urine.

Environmental analysis: Monitoring our environment- eg finding out the levels of various elements in rivers, seawater, drinking water, air, petrol and drinks such as wine, beer and fruit drinks.

Pharmaceuticals: In some pharmaceutical manufacturing processes, minute quantities of a catalyst used in the process (usually a metal) are sometimes present in the final product. By using AAS the amount of catalyst present can be determined.

Industry: Many raw materials are examined and AAS is widely used to check that the major elements are present and that toxic impurities are lower than specified- eg in concrete, where calcium is a major constituent, the lead level should be low because it is toxic.

Mining: By using AAS the amount of metals such as gold in rocks can be determined to see whether it is worth mining the rocks to extract the gold.

HOW IT WORKS

Atoms of different elements absorb characteristic wavelengths of light. Analysing a sample to see if it contains a particular element means using light from that element. For example with lead, a lamp containing lead emits light from excited lead atoms that produce the right mix of wavelengths to be absorbed by any lead atoms from the sample. In AAS, the sample is atomized- i.e. converted into ground state free atoms in the vapour state- and a beam of electromagnetic radiation emitted from excited lead atoms is passed through the vaporized sample. Some of the radiation is absorbed by the lead atoms in the sample. The greater the number of atoms there is in the vapour, the more radiation is absorbed. The amount of light absorbed is proportional to the number of lead atoms. A calibration curve is constructed by running several samples of known lead concentration under the same conditions as the unknown. The amount the standard absorbs is compared with the calibration curve and this enables the calculation of the lead concentration in the unknown sample.

Consequently an atomic absorption spectrometer needs the following three components: a light source; a sample cell to produce gaseous atoms; and a means of measuring the specific light absorbed.

THE LIGHT SOURCE

The common source of light is a 'hollow cathode lamp'. This contains a tungsten anode and a cylindrical hollow cathode made of the element to be determined. These are sealed in a glass tube filled with an inert gas- e.g neon or argon- at a pressure of between 1 Nm^{-2} and 5 Nm^{-2} .



The ionization of some gas atoms occurs by applying a potential difference of about 300-400V between the anode and the cathode. These gaseous ions bombard the cathode and eject metal atoms from the cathode in a process called sputtering. Some sputtered atoms are in excited states and emit radiation characteristic of the metal as they fall back to the ground state – $eg Pb^* \rightarrow Pb + h \nu$. The shape of the cathode concentrates the radiation into a beam which passes through a quartz window, and the shape of the lamp is such that most of the sputtered atoms are redeposited on the cathode. A typical atomic absorption instrument holds several lamps each for a different element. The lamps are housed in a rotating turret so that the correct lamp can be quickly selected.

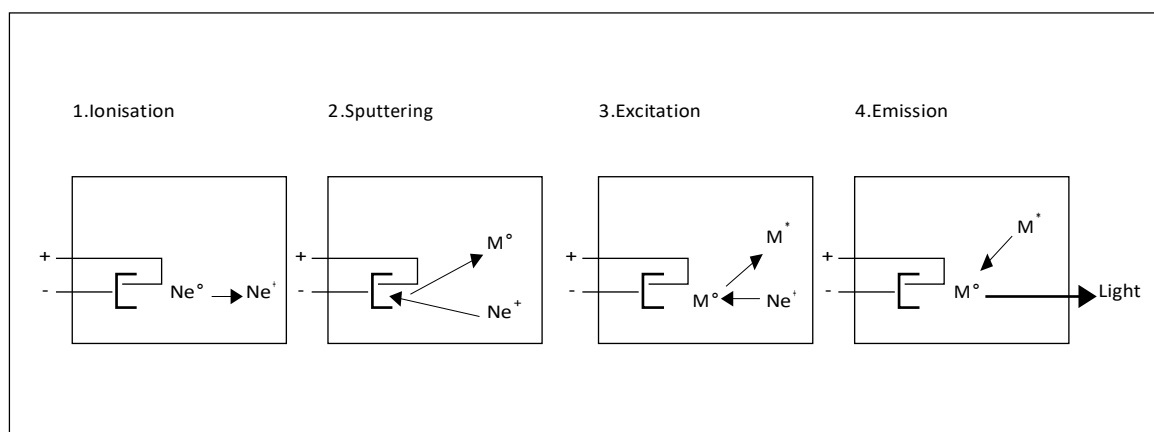

THE OPTICAL SYSTEM AND DETECTOR

A monochromator is used to select the specific wavelength of light –ie spectral line – which is absorbed by the sample, and to exclude other wavelengths. The selection of the specific light allows the determination of the selected element in the presence of others. The light selected by the monochromator is directed onto a detector that is typically a photomultiplier tube. This produces an electrical signal proportional to the light intensity

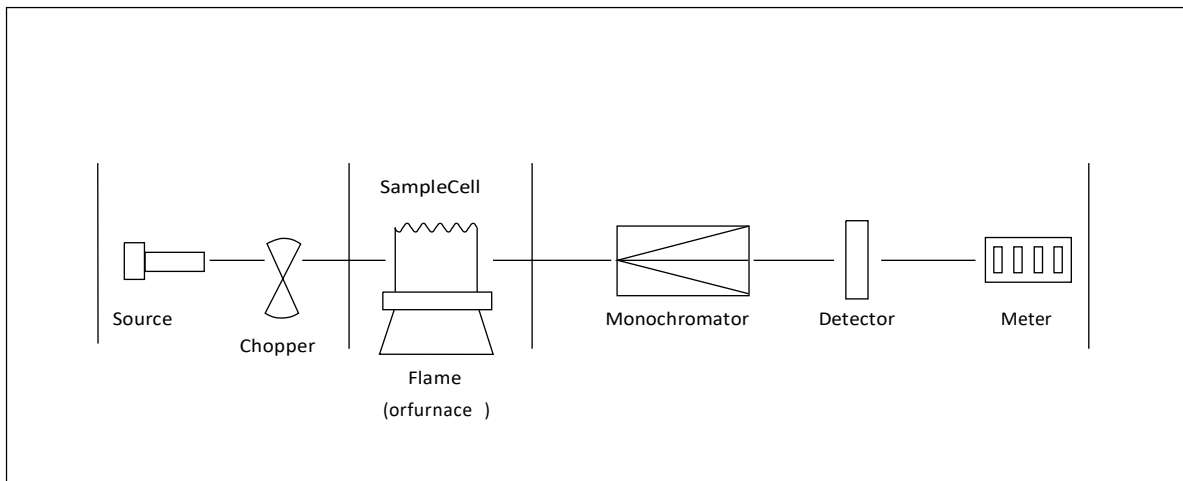

DOUBLE BEAM SPECTROMETERS

Modern spectrometers incorporate a beam splitter so that one part of the beam passes through the sample cell and the other is the reference. The intensity of the light source may not stay constant during an analysis. If only a single beam is used to pass through the atom cell, a blank reading containing no analyte (substance to be analysed) would have to be taken first, setting the absorbance at zero. If the intensity of the source changes by the time the sample is put in place, the measurement will be inaccurate. In the double beam instrument, there is a constant monitoring between the reference beam and the light source. To ensure that the spectrum does not suffer from loss of sensitivity, the beam splitter is designed so that as high a proportion as possible of the energy of the lamp beam passes through the sample.

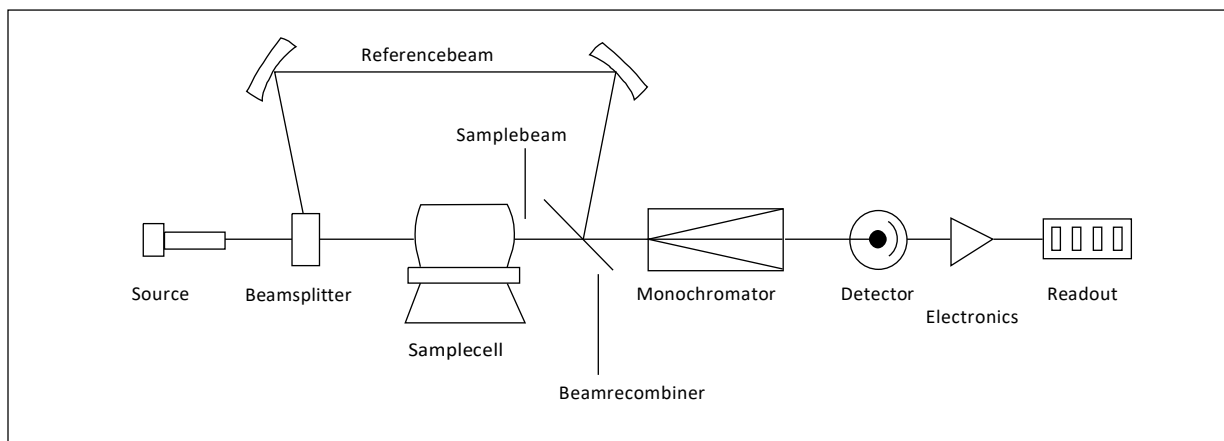

ATOMIZATION OF THE SAMPLE

Two systems are commonly used to produce atoms from the sample. Aspiration involves sucking a solution of the sample into a flame; and electrothermal atomization is where a drop of sample is placed into a graphite tube that is then heated electrically.

Some instruments have both atomization systems but share one set of lamps. Once the appropriate lamp has been selected, it is pointed towards one or other atomization system.

FLAME ASPIRATION

Ethyne/air (giving a flame with a temperature of 2200–2400°C) or ethyne/dinitrogen oxide (2600–2800°C) are often used. A flexible capillary tube connects the solution to the nebulizer. At the tip of the capillary, the solution is ‘nebulized’ –ie broken into small drops. The larger drops fall out and drain off while smaller ones vaporize in the flame. Only ca 1% of the sample is nebulized.

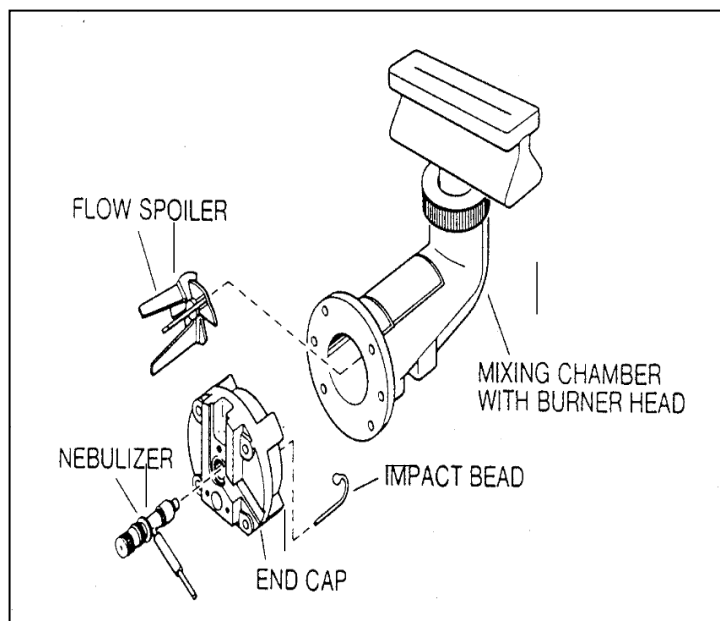

Figure 1

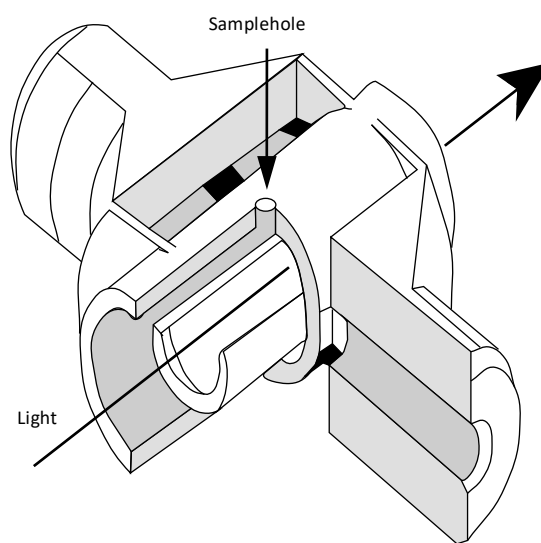

Figure 2

ELECTROTHERMAL ATOMIZATION

25 µl of sample (ca 1/100th of a raindrop) is placed through the sample hole and onto the platform from an automated micropipette and sample changer. The tube is heated electrically by passing a current through it in a pre-programmed series of steps. The details will vary with the sample but typically they

might be 30–40 seconds at 150°C to evaporate the solvent, 30 seconds at 600°C to drive off any volatile organic material and char the sample to ash, and with a very fast heating rate (ca 1500 °C s⁻¹) to 2000–2500°C for 5–10 seconds to vaporise and atomize elements (including the element being analysed). Finally heating the tube to a still higher temperature –ca 2700°C – cleans it ready for the next sample. During this heating cycle the graphite tube is flushed with argon gas to prevent the tube burning away. In electrothermal atomization almost 100% of the sample is atomised. This makes the technique much more sensitive than flame AAS.

SAMPLE PREPARATION

Sample preparation is often simple, and the chemical form of the element is usually unimportant. This is because atomization converts the sample into free atoms irrespective of its initial state. The sample is weighed and made into a solution by suitable dilution. Elements in biological fluids such as urine and blood are often measured simply after a dilution of the original sample.



When making reference solutions of the element under analysis, for calibration, the chemical environment of the sample should be matched as closely as possible –i.e., the analyte should be in the same compound and the same solvent. Teflon containers may be used when analysing very dilute Solutions because elements such as lead are sometimes leached out of glass vessels and can affect the results

BACKGROUND ABSORPTION

It is possible that other atoms or molecules apart from those of the element being determined will absorb or scatter some radiation from the light source. These species could include unvaporised solvent droplets, or compounds of the matrix (chemical species, such as anions, that tend to accompany the metals being analysed) that are not removed completely. This means that there is a background absorption as well as that of the sample.

One way of measuring and correcting this background absorption is to use two light sources, one of which is the hollow cathode lamp appropriate to the element being measured. The second light source is a deuterium lamp.

The deuterium lamp produces broad band radiation, not specific spectral lines as with a hollow cathode lamp. By alternating the measurements of the two light sources – generally at 50 –100 Hz – the total absorption (absorption due to analyte atoms plus background) is measured with the specific light from the hollow cathode lamp and the background absorption is measured with the light from the deuterium lamp. Subtracting the background from the total absorption gives the absorption arising from only analyte atoms.

CALIBRATION

A calibration curve is used to determine the unknown concentration of an element –eg lead – in a solution. The instrument is calibrated using several solutions of known concentrations. A calibration curve is produced which is continually rescaled as more concentrated solutions are used – the more concentrated solutions absorb more radiation up to a certain absorbance. The calibration curve shows the concentration against the amount of radiation absorbed in the given figure. (a) The sample solution is fed into the instrument and the unknown concentration of the element-e.g., lead- is then displayed on the calibration curve given in the below figure. (b)

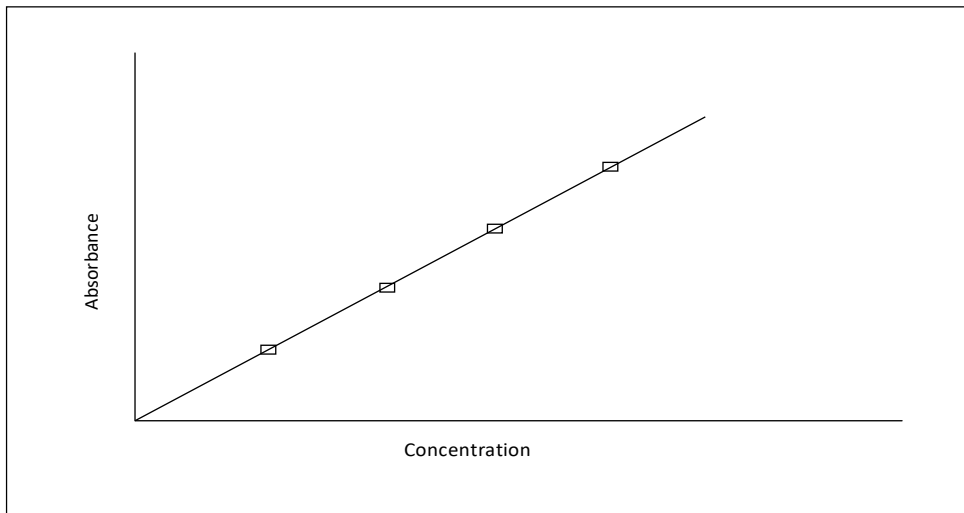

Figure (a)

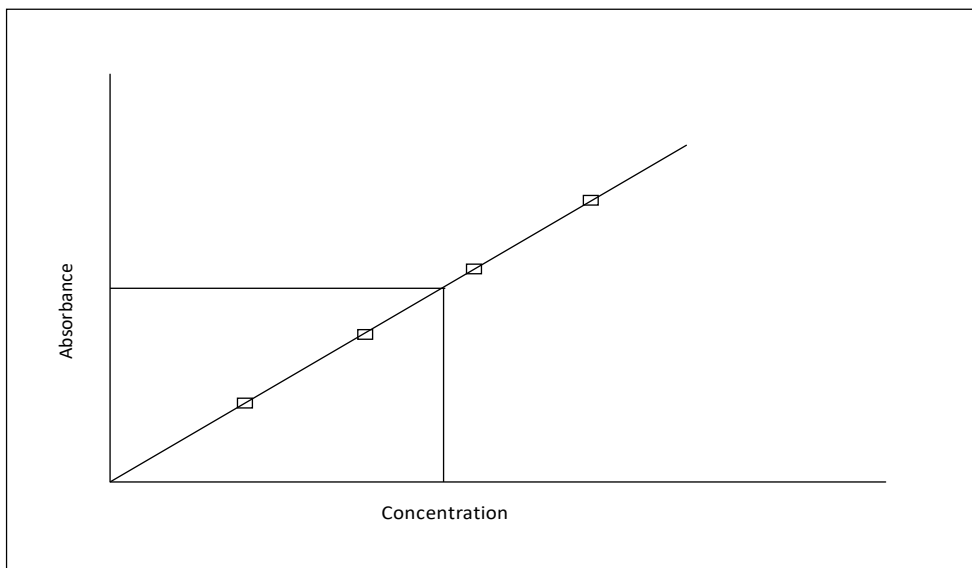

Figure (b)

Chapter-IV

METHODOLOGY

MATERIALS REQUIRED

- Ferric chloride Hexahydrate
- D-Ribose
- Bentonite
- Volumetric flask
- Digital Weighing Machine
- Watch glasses
- Hot air oven
- Ultra-pure water (Demineralized)
- 2% of Nitric acid

PROCEDURE

1. Using a 250ml Volumetric flask prepare a metal ligand solution by adding 100ppm of Ferric chloride Hexahydrate (MOLYCHEM MCR-11580) and 200ppm of D-Ribose (AVRAN2200133). Prepare 250ml solution by adding Ultra-pure water and then keep this system aside for a few hours.
2. Weigh 5 grams of Bentonite(AVRA N2101070) using a Digital weighing machine (Citizen Scales(I) PVT LTD CTG302-300) and take this into a beaker.
3. Now add 100ml of the above prepared metal ligand solution into the beaker and stir the mixture well for 10 minutes using a glass rod.
4. Keep this mixture aside for 48 hours without disturbing it as at this step Ferric is going to be adsorbed on Bentonite in the presence of D-Ribose which acts as a chelating agent.
5. After completion of 48 hours take the mixture and filter it off using Whatman Grade 1 filter paper and a funnel.

6. After filtration of the mixture again add Ultra-pure water for 3 times and then filtrate it to obtain pure concentration of Ferric which is get adsorbed on Bentonite.
7. Collect the filtered Bentonite powder and place it on a watch glass and keep this in a Hot air Owen at 60 °C for 10 hours to get rid of moisture present in it.
8. Now weigh each 1 gm of Bentonite in glass vials.
9. Now take a beaker and rinse it with ultra-pure water then followed by Nitric acid.
10. Take 0.5 grams of Bentonite sample in the beaker and add 2% of Nitric acid and stir the mixture well for 10-15 minutes.
11. Filter the mixture using Whatman Grade 1 filter paper and again 3 times by using Ultra-pure water to obtain pure concentration of Ferric present in the mixture prepared using the sample.
12. Take this collected sample solution and keep this system under AAS (Thermos Scientific iCE 3300)
13. Calculate the concentration of Ferric adsorbed on Bentonite at different ppm levels. Observe the graph obtained and note down the readings of the result we obtained.
14. Same Experiment carried out without the interference/addition of Ligand i.e. D-Ribose for Control Experiment.



Bentonite Powder

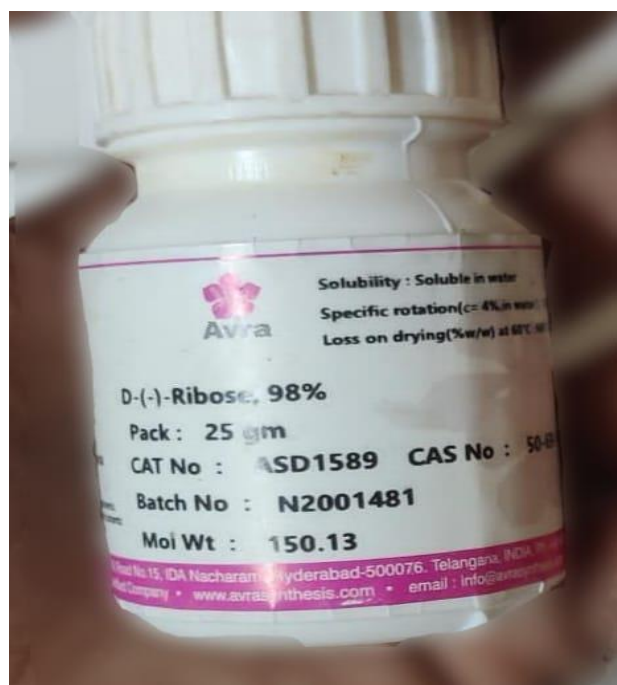

D – Ribose



FERRIC CHLORIDE (HEXAHYDRATE) $\text{FeCl}_3 \cdot 6\text{H}_2\text{O}$



Metal Ligand Solution



Watch Glass



Spatula



Digital Weighing Machine



Hot air Owen











ATOMIC ASORPTION SPECTROSCOPY

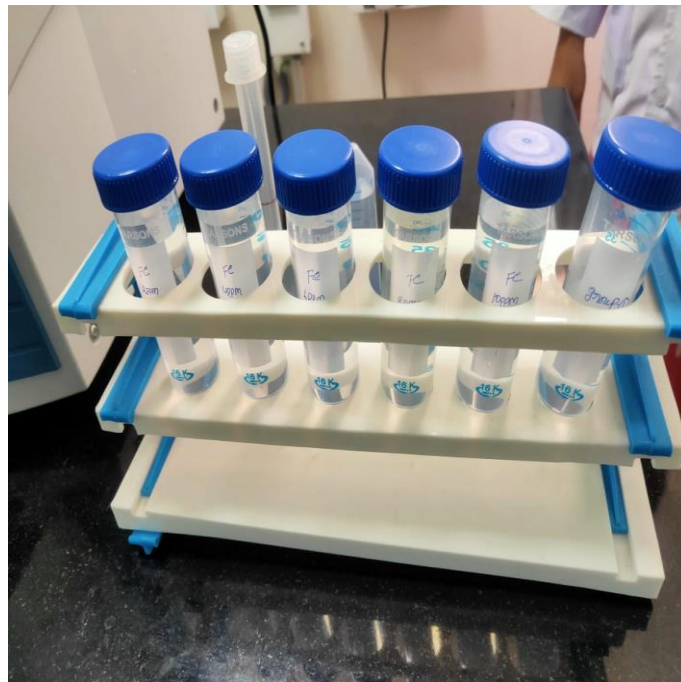

Fe standards with test sample

Chapter-V

RESULTS AND DISCUSSIONS

Bentonite adsorbs **807.5ppm** of Iron metal from aqueous solution of Fe(III)-D-Ribose metal ligand solution. Whereas, Bentonite adsorbs only **775.0ppm** when D-Ribose is absent. It is evident from the AAS results, ligand involvement enhanced the metal adsorption by initiating potential chemical interactions between adsorbate and adsorbent. D-Ribose firmly coordinates with Fe(III) to form a stable complex in aqueous condition. The complex coordination sphere in the resulted complex facilitates strong interactions with the polar points of Bentonite. From the AAS results, it is conclusive that **4.193%** of adsorption increased in the presence of D-Ribose as chelating agent.

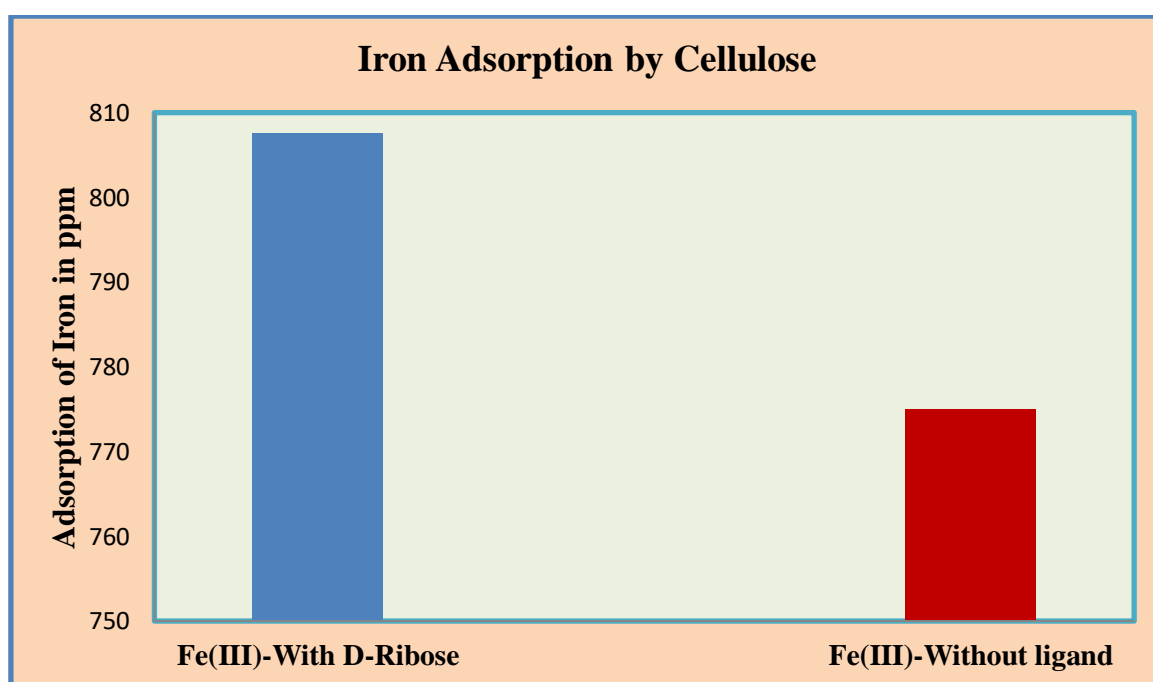

Impact of D-Ribose on Adsorption of Fe (III) ions from aqueous solution by Bentonite.

Spectrometer Parameters – Fe:

Element : Fe	Measurement mode : Absorbance	
Wavelength : 248.3nm	Band pass : 0.2nm	Lamp current : 75%
Background correction : D2	High Resolution : Off	Optimise Spectrometer Parameters : No
Signal type : continuous	Resamples : Fast	Number of resamples : 3
Measurement time : 4.0secs	Flier mode : No	
Use RSD Test : No		

Flame parameters – Fe:

Flame type : Air – C2H2	Fuel Flow : 0.9L/min	Auxiliary Oxidant : Off
Nebuliser Uptake : 4secs	Bunsen Stabilisation : 0mins	Optimise Fuel Flow : No
Burner Height : 7.0mm	Optimise Burner fuel : No	

Calibration Parameters – Fe:

Calibration mode : Normal	Line fit : Linear	Use stored calibration : No
Concentration units : mg/L	Scales units : mg/L	Scaling factor : 1.0000
Acceptable fit : 0.990	Rescale Limits : 10.0%	Failure Action : Flag and Continue
Standard 1 - 2.0000	Standard 4 - 8.0000	
Standard 2 - 4.0000	Standard 5 - 10.0000	
Standard 3 - 6.0000		

Solutions Results–Fe:

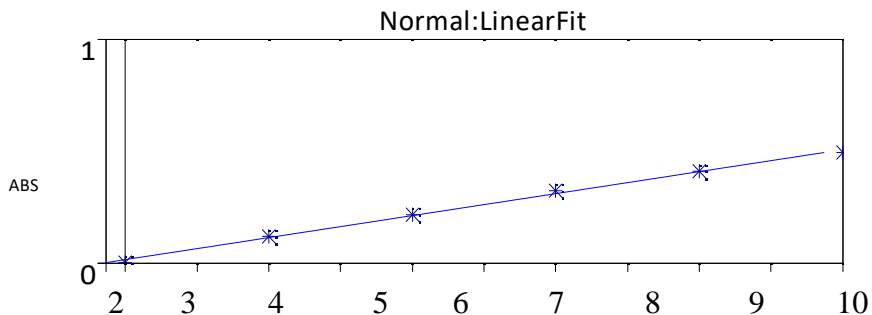

$Y = 0.04924x + 0.0141$

Fit: 0.9965

Characteristic Conc.: 0.0894

Sample ID	Signal	RSD	Conc.
	Abs	%	Mg/L
Fe Blank	0	<99	0
1	0	Background: 0.000	
2	0	Background: 0.000	
3	0	Background: 0.000	
Fe Standard 1	0.125	0.3	2
1	0.125	Background: 0.006	
2	0.125	Background: 0.006	
3	0.126	Background: 0.006	
Fe Standard 2	0.225	0.5	4
1	0.227	Background: 0.007	
2	0.225	Background:0.007	
3	0.224	Background:0.007	

Fe Standard 3	0.336	0.2	6
1	0.336	Background: 0.008	
2	0.336	Background: 0.008	
3	0.335	Background: 0.008	
Fe Standard 4	0.425	0.2	8
1	0.426	Background: 0.009	
2	0.425	Background: 0.008	
3	0.425	Background: 0.009	
Fe Standard 5	0.51	0.4	10
1	0.51	Background: 0.009	
2	0.509	Background: 0.009	
3	0.513	Background: 0.009	
Fe(III)-D-Ribose-Bentonite	0.809	0.2	16.1488 C
1	0.808	Background: 0.005	
2	0.809	Background: 0.005	
3	0.811	Background: 0.005	
Fe(III)-Bentonite (Without Ligand)	0.776	0.2	15.4988C
1	0.778	Background: 0.004	
2	0.775	Background: 0.004	
3	0.775	Background: 0.004	

TEST RESULTS:

S.No.	Test Parameters	Sample	Results
01.	Iron by AAS Analysis: (ppm)	Fe(III)- D-Ribose- Bentonite Sample	807.5ppm
02.	Iron by AAS Analysis: (ppm)	Fe(III)-Bentonite (control)	775.0ppm

CONCLUSION

From the current project it is clear that D-Ribose as a Chelating agent has played a vital role in adsorption of Fe(III) ions from aqueous solution and increases the adsorption up to **4.193 %**. This aspect will be useful in designing the newer strategies of Heavy metal Remediation techniques using Natural Chelating Ligands as Facilitating agents in Metal Adsorption processes.

REFERENCES

- [1] A. Tzschach, K. Ponick, L. Korecz and K. Burger, *J. Organomet. Chem.*, **59**, 199 (1973).
- [2] A. D. Buckingham, *Can. J. Chem.* **1960**, *38*, 300-307
- [3] A. F. Cotton and G. Wilkinson, *Advanced Inorganic Chemistry*, 6th edition, John Wiley & Sons, **1999**, p. A. Martinez, J. Suarez, T. Shand, R. S. Magliozzo and R. A. Sanchez Delgado, *J. Inorg. Biochem.* **2011**, *105*, 39-45; S. S. Hosseini, M. Bhadbhade, R. J. Clarke, P. J. Rutledge and L. M. Rendina, *Dalton Trans.* **2011**, *40*, 506-513.
- [4] A. Bentz, P. Comba, R. J. Deeth, M. Kerscher, B. Seibold and H. Wadepohl, *Inorg. Chem.* **2008**, *47*, 9518-9527; C. Diedrich and R. J. Deeth, *Inorg. Chem.* **2008**, *47*, 2494-2506; L. Bonniard, A. de la Lande, S. Ulmer, J.-P. Piquemal, O. Parisel and H. Gérard, *Catalysis Today* **2011**, *177*, 79-86; Y. D. M. Champouret, J.-D. Maréchal, I. Dadhiwala, J. Fawcett, D. Palmer, K. Singh and G. A. Solan, *Dalton Trans.* **2006**, 2350-2361.
- [5] A. D. Becke, *J. Chem. Phys.* **1993**, *98*, 5648-5652.
- [6] B. Lakatos, I. Meisel, A. Rockenbauer, P. Simon and L. Korecz, *J. Inorg. Chim. Acta*, **79**, 269 (1983).
- [7] B. Chiari, O. Piovesana, T. Tarantelli and P. F. Zanazzi, *J. Inorg. Chem.*, **22**, 2781 (1983), and refs. There B. P. Hay and R. D. Hancock, *Coord. Chem. Rev.* **2001**, *212*, 61-78.
- [8] C. Gessa, M. L. De Cherchi, A. Dessi, S. Deiana and G. Micera, *Inorg. Chim. Acta*, **80**, L53 (1983).
- [9] C. F. Macrae, P. R. Edgington, P. McCabe, E. Pidcock, G. P. Shields, R. Taylor, M. Towler and J. v. d. Streek, *J. Appl. Cryst.* **2006**, *39*, 453-457
- [10] C. A. G. Haasnoot, F. A. A. M. de Leeuw and C. Altona, *Tetrahedron* **1980**, *36*, 2783-1792. C. A. Podlasek, J. Wu, W. A. Stripe, P. B. Bondo and A. S. Serianni, *J. Am. Chem. Soc.* **1995**, *117*, 8635-8644.
- [11] C. Lee, W. Yang and R. G. Parr, *Phys. Rev. B* **1988**, *37*, 785-789.

- [12] D. J. Cram and J. M. Cram, *Container Molecules and their Guests*, The Royal Society of Chemistry, Cambridge, **1994**, p; J. B. Wittenberg and L. Isaacs in *Complementarity and Preorganization*, (Ed. J. W. S. Philip A. Gale), John Wiley and Sons, **2012**.
- [13] D. Cremer and J. A. Pople, *J. Am. Chem. Soc.* **1975**, 97,1354-1358.
- [14] D. E. Wilcox, *Inorg. Chim. Acta* **2008**, 361, 857-867; A. Trapaidze, C. Hureau, W. Bal, M. Winterhalter and P. Faller, *J. Biol. Inorg. Chem.* **2012**, 17,37-47.
- [15] D. W. Johnson and K. N. Raymond, *Supramol. Chem.* **2001**, 13,639-659.
- [16] E. Chekmeneva, R. Prohens, J. M. Díaz-Cruza, C. Ariñoa and M. Esteban, *Anal. Biochem.* **2008**, 375, 82-89.
- [17] F.W.Lichtenthaler, *Acc.Chem.Res.* **2002**, 35,728-737; M.J.Climent, A.Corma and S.Iborra, *Green Chem.* **2011**, 13, 520-540.
- [18] F. Bellot, R. Hardré, G. Pelosi, M. Thérísod and C. Policar, *Chem. Commun.* **2005**,5414-5416.
- [19] F. Cisnetti, R. Guillot, G. Pelosi, M. Desmadril and C. Policar, *Dalton Trans.* **2007**,1473-1476.
- [20] F. Cisnetti, R. Guillot, M. Thérísod and C. Policar, *Acta Cryst.* **2007**, C63,m201-m203.
- [21] F.Cisnetti,R.Guillot,N.Ibrahim,F.Lambert,M.Thérísod and C.Policar, *Carbohydr.Res.* **2008**,343,530-535.
- [22] F. Cisnetti, R. Guillot, M. Thérísod, M. Desmadril and C. Policar, *Inorg. Chem.* **2008**, 47,2243-2245.
- [23] F. E. Jorge, J. Autschbach and T. Ziegler, *J. Am. Chem. Soc.* **2005**, 127, 975-985; E. I. Stiefel and G. F. Brown, *Inorg. Chem.* **1972**, 11,434-436.
- [24] F. Mohamadi, N. G. J. Richard, W. C. Guida, L. R., M. Lipton, C. Caufield, G. Chang, T. Hendrickson and W. C. Still, *J. Comput. Chem.* **1990**, 11,440-467.
- [25] G.Micera,S.Deiana,C.Gessa and M.Petrera, *Inorg. Chim. Acta*, 56, 109 (1981).
- [26] G. Charron, F. Bellot, F. Cisnetti, G. Pelosi, J.-N. Rebilly, E. Rivière, A.-L. Barra, T. Mallah and C. Policar, *Chem. Eur. J.* **2007**, 13,2774-2782.
- [27] G. Camci-Unal and N. L. B. Pohl, *Carbohydr. Polym.* **2010**, 81, 8-13; S. Striegler and M. G. Gichinga, *Chem. Commun.* **2008**,5930-5932.
- [28] G. Sheldrick, *SHELXS-97 Program for Crystal Structure Refinement*, **1997**.
- [29] G. Sheldrick, *SHELXL-97 Program for Crystal Structure Refinement*, **1997**.
- [30] G. L. Strati, J. L. Willett and F. A. Momany, *Carbohydr. Res.* **2002**, 337,1833-1849.
- [31] H. M. Irving and R. J. P. Williams, *J. Chem. Soc.* **1953**,3192-3210.
- [32] H. D. Flack, *Acta Cryst.* **1983**, A39, 876-881.
- [33] I.Zay,A.Vertes,G.Takacs Nagy,M.Suba and K.Burger, *Radioanal.Nuc/.Chem.*,88,343(1985).
- [34] I. Berger, M. Hanif, A. A. Nazarov, C. G. Hartinger, R. O. John, M. L. Kuznetsov, M. Groessl, F. Schmitt, O. Zava, F. Biba, V. B. Arion, M. Galanski, M. A. Jakupec, L. Juillerat-Jeanneret, P

J. Dyson and B. K. Keppler, *Chem. Eur. J.* **2008**, *14*, 9046-9057; M. Gottschaldt, U. S. Schubert, S. Rau, S. Yano, J. G. Vos, T. Kroll, J. Clement and I. Hilger, *ChemBioChem* **2010**, *11*, 649-652; M. Hanif, S. M. Meier, W. Kandioller, A. Bytzeck, M. Hejl, C. G. Hartinger, A. A. Nazarov, V. B. Arion, M. A. Jakupec, P. J. Dyson and B. K. Keppler, *J. Inorg. Biochem.* **2011**, *105*, 224-231; M. Hanif, A. A. Nazarov, C. G. Hartinger, W. Kandioller, M. A. Jakupec, V. B. Arion, P. J. Dyson and B. K. Keppler, *Dalton Trans.* **2010**, *39*, 7345-7352; J. K. H. Hui, Z. Yu, T. Mirfakhrai and M. J. MacLachlan, *Chem. Eur. J.* **2009**, *15*, 13456-13465; R. Kikkeri, D. Grünstein and P. H. Seeberger, *J. Am. Chem. Soc.* **2010**, *132*, 10230-10232; M.-W. Louie, H.-W. Liu, M. H.-C. Lam, Y.-W. Lam and K. K.-W. Lo, *Chem. Eur. J.* **2011**, *17*, 8304-8308; Y. Mikata, S. Fujii, M. Naemura, K. Takahashi and Y. Noguchi, *Dalton Trans.* **2009**, 10305-10310; T. Shibata, H. Hashimoto, I. Kinoshita, S. Yano and T. Nishioka, *Dalton Trans.* **2011**, *40*, 4826-4829; T. Storr, L. E. Scott, M. L. Bowen, D. E. Green, K. H. Thompson, H. J. Schugar and C. Orvig, *Dalton Trans.* **2009**, 3034-3043; C.-C. Yang, P.-S. Lin, F.-C. Liu, I. J. B. Lin, G.-H. Lee and S.-M. Peng, *Organometallics* **2010**, *29*, 5959-5971; E. C. Constable, C. E. Housecroft, M. Neuburger and P. Rosel, *Chem. Commun.* **2010**, *46*, 1628-1630.

[35] In this Paper, solvation issues are not discussed, however as we consider two ligands with the same coordinating sites and their interactions with metal cations possessing the same charge, solvation effects could most confidently be neglected while discussing the metal selectivities in this study. , Vol.

[36] Ju. A. Komkov, M. A. Ivanov, G. A. Shagisultanova and Ju. B. Jakovlev, *Zh. Neorg. Khim.*, **29**, 15202 (1984).

[37] J.-H. Liao, C.-S. Chen, C.-C. Hu, W.-T. Chen, S.-P. Wang, I. L. Lin, Y.-H. Huang, M.-H. Tsai, T.-H. Wu, F.-Y. Huang and S.-H. Wu, *Inorg. Chem.* **2011**, *50*, 365-377; P. G. Devi, S. Pal, R. Banerjee and D. Dasgupta, *J. Inorg. Biochem.* **2007**, *101*, 127-137.

[38] J. Ali-Torres, J.-D. Maréchal, L. Rodriguez-Santiago and M. Sodupe, *J. Am. Chem. Soc.* **2011**, *133*, 15008-15014; V. Muñoz Robles, E. Ortega-Carrasco, E. G. Fuentes, A. Lledos and J.-D. Maréchal, *Faraday Discuss.* **2011**, *148*, 137-159.

[39] K. Burger, I. Zay and G. Takacs Nagy, *Inorg. Chim. Acta*, **80**, 231 (1983).

[40] K. Born, P. Comba, R. Ferrari, G. A. Lawrance and H. Wadepohl, *Inorg. Chem.* **2007**, *46*, 458-464.

[41] L. Garcia, S. Maisonneuve, J. Xie, R. Guillot, P. Dorlet, E. Rivière, M. Desmadril, F. Lambert and C. Policar, *Inorg. Chem.* **2010**, *49*, 7282-7288.

[42] L. Garcia, S. Maisonneuve, J. Oudinet-Sin Marcu, R. Guillot, F. Lambert, J. Xie and C. Policar, *Inorg. Chem.* **2011**, *50*, 11353-11362.

[43] L. J. Farrugia, *J. Appl. Cryst.* **1999**, *32*, 837-838.

[44] M. Tonkovic, S. Music, I. Hadzija, J. Nagy-Czak and A. Vertes, *Acta Chim. Hung.*, **110**, 197 (1982).

- [45] M. M. K. Boysen, *Chem. Eur. J.* **2007**, *13*, 8648-8659.
- [46] M. Gottschaldt and U. S. Schubert, *Chem. Eur. J.* **2009**, *15*, 1548-1557; M. L. Bowen and C. Orvig, *Chem. Commun.* **2008**, 5077-5091.
- [47] *Chem. Eur. J.* **2010**, *16*, 10202-10213; A. H. Younes, L. Zhang, R. J. Clark and L. Zhu, M. Ostermeier, M.-A. Berlin, R. M. Meudtner, S. Demeshko, F. Meyer, C. Limberg and S. Hecht, *J. Org. Chem.* **2009**, *74*, 8761-8772; L. Zhang and L. Zhu, *J. Org. Chem.* **2008**, *73*, 8321-8330; N. K. Dalley, U. Olsher, J. C. Lee, M. D. Eley, J. Wang and R. A. Bartsch, *Tetrahedron* **2007**, *63*, 10576-10580; L. Mikulášek, B. Grüner, C. Dordea, V. Rudzевич, V. Böhmer, J. Haddaoui, V. Hubscher-Bruder, F. Arnaud-Neu, J. Čáslavský and P. Selucký, *European J. Inorg. Chem.* **2007**, *2007*, 4772-4783; P. Comba, N. Dovalil, G. Haberhauer, G. Hanson, Y. Kato and T. Taura, *J. Biol. Inorg. Chem.* **2010**, *15*, 1129-1135.
- [48] M. Miguiretichian, D. Guillauneux, D. Guillaumont, P. Moisy, C. Madic, M. P. Jensen and L. Nash, *Inorg. Chem.* **2005**, *44*, 1404-1412. M. J. Frisch, G. W. Trucks, H. B. Schlegel, G. E. Scuseria, M. A. Robb, J. R. Cheeseman, J. J. A. Montgomery, T. Vreven, K. N. Kudin, J. C. Burant, J. M. Millam, S. S. Iyengar, J. Tomasi, V. Barone, B. Mennucci, M. Cossi, G. Scalmani, N. Rega, G. A. Petersson, H. Nakatsuji, M. Hada, M. Ehara, K. Toyota, R. Fukuda, J. Hasegawa, M. Ishida, T. Nakajima, Y. Honda, O. Kitao, H. Nakai, M. Klene, X. Li, J. E. Knox, H. P. Hratchian, J. B. Cross, V. Bakken, C. Adamo, J. Jaramillo, R. Gomperts, R. E. Stratmann, O. Yazyev, A. J. Austin, R. Cammi, C. Pomelli, J. W. Ochterski, P. Y. Ayala, K. Morokuma, G. A. Voth, P. Salvador, J. J. Dannenberg, V. G. Zakrzewski, S. Dapprich, A. D. Daniels, M. C. Strain, O. Farkas, D. K. Malick, A. D. Rabuck, K. Raghavachari, J. B. Foresman, J. V. Ortiz, Q. Cui, A. G. Baboul, S. Clifford, J. Cioslowski, B. B. Stefanov, G. Liu, A. Liashenko, P. Piskorz, I. Komaromi, R. L. Martin, D. J. Fox, T. Keith, M. A. Al-Laham, C. Y. Peng, A. Nanayakkara, M. Challacombe, P. M. W. Gill, B. Johnson, W. Chen, M. W. Wong, C. Gonzalez and J. A. Pople, *Gaussian03*, Gaussian, Inc., Wallingford CT, **2004**.
- [49] N. Ghaschghaie, T. Hoffmann, M. Steinborn and P. Klufers, *Dalton Trans.* **2010**, *39*, 5535-5543; A. L. Petrou, *Coord. Chem. Rev.* **2002**, *228*, 153-162.
- [50] P. Saltman, *J. Chem. Educ.*, *42*, 682 (1965).
- [51] P. J. Charley, B. Sarkar, C. F. Stitt and P. Saltman, *Biochim. Biophys. Acta*, *69*, 313 (1963).
- [52] P. Comba, *Coord. Chem. Rev.* **1999**, *182*, 343-371; P. Comba and W. Schiek, *Coord. Chem. Rev.* **2003**, *238-239*, 21-29.
- [53] P. Comba, T. W. Hambley and B. Martin, *Molecular Modeling of inorganic compounds*, 3rd edition, Wiley VCH Weinheim, **2010**, p.
- [54] P. Comba, *Coord. Chem. Rev.* **1999**, *185-186*, 8198; P. Comba and M. Kerscher, *Coord. Chem. Rev.* **2009**, *253*, 564-574.
- [55] P. J. Hay and W. R. Wadt, *J. Chem. Phys.* **1985**, *82*, 299-310.

- [56] R. D. Hancock, D. L. Melton, J. M. Harrington, F. C. McDonald, R. T. Gephart, L.L.Boone, S.B. Jones,
- [57] N. E. Dean, J. R. Whitehead and G. M. Cockrell, *Coord. Chem. Rev.* **2007**, 251,1678-1689.
- [58]R. Deeth and C. Diedrich, *J. Biol. Inorg. Chem.* **2009**, 15, 117-129' N.Gresh G. A. Cisneros,T. A. Darden and J. P. Piquemal, *J. Chem. Theory Comput.* **2007**, 3 ,1960-1986.
- [59] R. J. Deeth, A. Anastasi, C. Diedrich and K. Randell, *Coord. Chem. Rev.* **2009**, 253,795-816.
- [60] R. D. Hancock and K. Hegetschweiler, *J. Chem. Soc., Dalton Trans.* **1993**,2137-2140.
- [61] R. Jeanloz, H. G. Fletcher and C. S. Hudson, *J. Am. Chem. Soc.* **1948**, 70,4052-4054.
- [62] R. D. Shannon, *Acta Cryst.* **1976**, A32, 751-767.
- [63]S.WolowiecandK. Drabent, *J.Radioanal.Nucl. Chem. Lett.*, 95, 1 (1985).
- [64]S.Dhungana,J.M.Harrington,P.Gebhardt,U.MöllmannandA.L.Crumbliss,*Inorg.Chem.***2007**,46,8362-8371.
- [65] S. Woodward, M. Diéguez and O. Pàmies, *Coord. Chem. Rev.* **2010**, 254,2007-2030.
- [66] S. J. Angyal, *Tetrahedron* **1974**, 30, 1695-1702; S. J. Angyal, *Chem. Soc. Rev.* **1980**, 9, 415-428; S. J. Angyal, *Aust. J. Chem.* **2000**, 53, 567-570; B. Gyurcsick and L. Nagy, *Coord. Chem. Rev.* **2000**, 203, 81- 149; N. Nagy and A. Szoresik, *J. Inorg. Biochem.* **2002**, 89, 1-12; J.-F. Verchèreand S. Chapelle, *Progr. Inorg. Chem.* **1998**, 47, 837-945; D. M. Whitfield, S. Stojkovski and B. Sarkar, *Coord. Chem. Rev.* **1993**, 122, 171-225.
- [67] S. J. Angyal, *Adv. Carbohydr. Chem. Biochem.* **1989**, 47,1-43.
- [68] S. Bjelić and I. Jelesarov, *J. Mol. Recognit.* **2009**, 21, 289-312; R. J. Falconer and B. M. Collins, *J. Mol. Recognit.* **2011**, 24, 1-16; R. J. Falconer, A. Penkova, I. Jelesarov and B. M. Collins, *J. Mol. Recognit.* **2010**, 23, 395-413; O. Okhrimenko and I. Jelesarov, *J. Mol. Recognit.* **2008**, 21,1-19.
- [69] Schrodinger, Inc., Portland, Oregon,2000,
- [70] T. K. Lindhorst, *Essentials of Carbohydrate Chemistry and Biochemistry*, Wiley-VCH, **2003**,p.
- [71] T.Marino,N.Russo and M Toscano,*J.Inorg. Biochem.* **2000**,79,179-185;J.Bertran,L. Rodriguez-Santiago and M. Sodupe, *J. Phys. Chem. B* **1999**, 103,2310-2317.
- [72] The use of unprotected sugar polyols or polyolate as ligands, while not discussed here in detail, is conceptually related to our work. For a review see: T. Allscher, P. Klüfers,
- [73]P.Mayerin:B.Fraser-Reid,K. Tatsuta, J. Thiem(eds.) in *Glycoscience*,Spring Verlag, Berlin, **2008**, 1079–1139., Vol.
- [74]V. J. James, J. D. Stevens and F. H. Moore, *Acta Cryst.* **1978**, B34,188-193.
- [75] W. O. Gillum, R. A. D. Wentworth and R. F. Childers, *Inorg. Chem.* **1970**, 9,1825-1832.
- [76] W. Jorgensen, D. Maxwell and J. Tirado-Rives, *J. Am. Chem. Soc.* **1996**, 118, 11225-11236.
- [77] W.J.Hehre,R.DitchfieldandJ.A.Pople,*J.Chem.Phys.***1972**,56,2257-2261;P.C.Hariharanand
- [78] J. A. Pople, *Theor. Chim. Acta* **1973**, 28, 213-222.
- [79]Z.Jingkun,L.Rongehuan,W.Shuxin,X.YuanfuandQ.Shouren,*KexueTongbao*,29,1091(1984).

MART SPECIALITIES LAB LLP.

Operator Name: Jyothi

Report Date: 11-06-2022 17:40:20

Results File: E:\AAS System Data\2022\JUNE\11 06 2022\TARA 0064 2-6\Iron (Fe)1.SLR

General Parameters

Method : Iron (Fe)

Operator : Jyothi

Instrument Mode: Flame

Autosampler : None

Dilution: None

Use SFI: No

Valid Method Signatures

11-06-2022 17:22:33 jyothi(M. Jyothi):DESKTOP-39TDEGC

Signed with Reason : Analysed by:

11-06-2022 17:23:24 parjanya(Parjanya):DESKTOP-39TDEGC

Signed with Reason : Approved by:

Method Audit Trail

11-06-2022 17:22:18 Jyothi(M. Jyothi):DESKTOP-39TDEGC

Record created

11-06-2022 17:22:33 jyothi(M. Jyothi):DESKTOP-39TDEGC

Signed with Reason : Analysed by:

11-06-2022 17:23:24 parjanya(Parjanya):DESKTOP-39TDEGC

Signed with Reason : Approved by:

Analysis Details

Analysis Name: Iron (Fe) 11-06-2022

Spectrometer: ICE 3000 AA01204906 v1.30

Operator Name: Jyothi

Lamp Information

Element(s)

Serial Number

mA Hours

Fe

n/a

n/a

Deuterium Lamp Hours: 68.34

Sequence Table

Shared Standards: Yes

Action	Fe
Calibration	✓
B.No.Group-II	✓
B.No.Group-III	✓
B.No.Group-IV	✓
B.No.Group-V	✓
B.No.Group-VI	✓

Sample Details

Nominal Mass: 1.0000

No.	Sample Id	Sample Mass	Dilution Ratio
1	B.No.Group-II	1.0000	1.0000
2	B.No.Group-III	1.0000	1.0000
3	B.No.Group-IV	1.0000	1.0000
4	B.No.Group-V	1.0000	1.0000
5	B.No.Group-VI	1.0000	1.0000

Valid Analysis Signatures

11-06-2022 17:38:41 jyothi(M. Jyothi):DESKTOP-39TDEGC

Signed with Reason : Analysed by:

11-06-2022 17:39:33 parjanya(Parjanya):DESKTOP-39TDEGC

Signed with Reason : Approved by:

Analysis Audit Trail

11-06-2022 17:30:16 Jyothi(M. Jyothi):DESKTOP-39TDEGC

Record created

11-06-2022 17:38:27 Jyothi(M. Jyothi):DESKTOP-39TDEGC

Error MD147 - Activity manually aborted by user.

11-06-2022 17:38:41 jyothi(M. Jyothi):DESKTOP-39TDEGC

Signed with Reason : Analysed by:

11-06-2022 17:39:33 parjanya(Parjanya):DESKTOP-39TDEGC

Signed with Reason : Approved by:

MART SPECIALITIES LAB LLP.

Operator Name: Jyothi

Report Date: 11-06-2022 17:40:20

Results File: E:\AAS System Data\2022\JUNE\11 06 2022\TARA 0064 2-6\Iron (Fe)1.SLR

Spectrometer Parameters - Fe

Element: Fe

Measurement Mode: Absorbance

Wavelength: 248.3nm

Bandpass: 0.2nm

Lamp Current: 75%

Background Correction: D2

High Resolution: Off

Optimise Spectrometer Parameters: No

Signal Type: Continuous

Resamples: Fast

Number Of Resamples: 3

Measurement Time: 4.0secs

Flier Mode: No

Use RSD Test: No

Flame Parameters - Fe

Flame Type: Air-C2H2

Fuel Flow: 0.9L/min

Auxiliary Oxidant: Off

Nebuliser Uptake: 4secs

Burner Stabilisation: 0mins

Optimise Fuel Flow: No

Burner Height: 7.0mm

Optimise Burner Height: No

Sampling Parameters - Fe

Sampling: None

Calibration Parameters - Fe

Calibration Mode: Normal

Line Fit: Linear

Use Stored Calibration: No

Concentration Units: mg/L

Scaled Units: mg/L

Scaling Factor: 1.0000

Acceptable Fit: 0.990

Rescale Limit: 10.0%

Failure Action: Flag and Continue

Standard 1	2.0000
Standard 2	4.0000
Standard 3	6.0000

Standard 4	8.0000
Standard 5	10.0000

Element Audit Trail - Fe

No changes are recorded for this element

Solution Results - Fe

$$Y = 0.04924x + 0.0141$$

Fit: 0.9965

Characteristic Conc: 0.0894

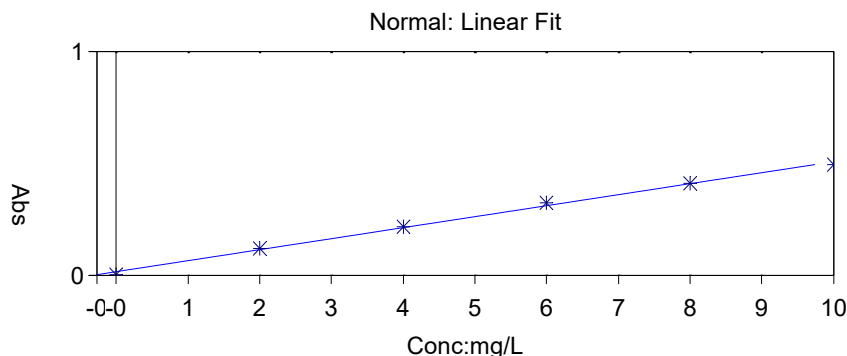

Sample ID	Signal	Rsd	Conc	Corrected Conc
	Abs	%	mg/L	mg/L
Fe Blank	0.001	35.6	0.0000	
1	0.001	Background: -0.003		11-06-2022 17:31:26
2	0.001	Background: -0.003		11-06-2022 17:31:30
3	0.000	Background: -0.003		11-06-2022 17:31:35
Fe Standard 1	0.120	0.3	2.0000	
1	0.120	Background: 0.003		11-06-2022 17:32:05
2	0.119	Background: 0.003		11-06-2022 17:32:09
3	0.120	Background: 0.003		11-06-2022 17:32:13
Fe Standard 2	0.215	0.3	4.0000	
1	0.215	Background: 0.004		11-06-2022 17:32:40
2	0.215	Background: 0.004		11-06-2022 17:32:45
3	0.216	Background: 0.004		11-06-2022 17:32:49
Fe Standard 3	0.322	0.2	6.0000	
1	0.323	Background: 0.005		11-06-2022 17:33:19
2	0.322	Background: 0.005		11-06-2022 17:33:23
3	0.322	Background: 0.005		11-06-2022 17:33:27
Fe Standard 4	0.411	0.3	8.0000	
1	0.410	Background: 0.005		11-06-2022 17:33:59
2	0.412	Background: 0.005		11-06-2022 17:34:03
3	0.412	Background: 0.005		11-06-2022 17:34:07

MART SPECIALITIES LAB LLP.

Operator Name: Jyothi

Report Date: 11-06-2022 17:40:20

Results File: E:\AAS System Data\2022\JUNE\11 06 2022\TARA 0064 2-6\Iron (Fe)1.SLR

Solution Results - Fe

Sample ID	Signal	Rsd	Conc	Corrected Conc
	Abs	%	mg/L	mg/L
Fe Standard 5	0.493	0.1	10.0000	
1	0.494	Background: 0.005		11-06-2022 17:34:38
2	0.494	Background: 0.005		11-06-2022 17:34:42
3	0.493	Background: 0.006		11-06-2022 17:34:46
Fe B.No.Group-II	0.834	0.1	16.6490 C	16.6490 C
1	0.834	Background: 0.005		11-06-2022 17:35:14
2	0.833	Background: 0.005		11-06-2022 17:35:19
3	0.834	Background: 0.005		11-06-2022 17:35:23
Fe B.No.Group-III	0.759	0.1	15.1286 C	15.1286 C
1	0.758	Background: 0.003		11-06-2022 17:35:52
2	0.760	Background: 0.003		11-06-2022 17:35:56
3	0.758	Background: 0.004		11-06-2022 17:36:00
Fe B.No.Group-IV	0.645	0.3	12.8189 C	12.8189 C
1	0.647	Background: 0.003		11-06-2022 17:36:31
2	0.644	Background: 0.003		11-06-2022 17:36:35
3	0.645	Background: 0.003		11-06-2022 17:36:40
Fe B.No.Group-V	0.809	0.2	16.1488 C	16.1488 C
1	0.808	Background: 0.005		11-06-2022 17:37:11
2	0.809	Background: 0.005		11-06-2022 17:37:15
3	0.811	Background: 0.005		11-06-2022 17:37:20
Fe B.No.Group-VI	0.711	0.3	14.1597 C	14.1597 C
1	0.709	Background: 0.005		11-06-2022 17:37:55
2	0.713	Background: 0.005		11-06-2022 17:37:59
3	0.712	Background: 0.004		11-06-2022 17:38:03

MART Specialities Lab. LLP

Work : Road No. : 03, Plot No.: 31, Ground Floor & 1st Floor, Gajularamaram, ALEAP Industrial Area,
Pragathi Nagar, Medhcal, Medchal-Malkajgiri - 500 055, Telangana, India,
Tel. : 85007 98350, 81423 98350 & 98481 98350 Mail:martspecialities@gmail.com



DCA Approval No: 05/ML/TS/2020/G

CERTIFICATE OF ANALYSIS

MSL/QA/017-03/F07-00

Name & Address of the Customer: Tara Government College Prashanth Nagar Colony, Balajinagar Sangareddy Telangana. 502000 Contact Person: Dr. Abhijeet Contact Number :9502344392	Reference / Report No. : MSL/2022/JUNE/TARA/0064-1 Sample Received Date : 11/06/2022 Report Date : 13/06/2022
---	--

DETAILS OF THE SAMPLE

Sample Name	: NA	Mfg.	: NA	Exp.	: NA
Name of the Manufacturer	: NA	date		date	
Batch no	: Group-I	Batch		size	: NA
Storage condition	: To be stored at room Temperature				
Room Temperature	: 25°C±3°C				
Quantity Received	: 4gm				
Tests Required	: Iron by AAS Analysis.				
Method	: NA				
Analysis Starting Date	: 11/06/2022				
Analysis Completion Date	: 11/06/2022				
Mfg. License No.	: Not provided				
A.R.NO	: NA				
Remark	: Sample analyzed as received				

Test Results

S.No.	Test Parameter	Result
01.	Iron by AAS Analysis: (ppm)	620ppm

Authorized Signatory

(Dr.R.Marayya)

MART Specialities Lab. LLP

Work : Road No. : 03, Plot No.: 31, Ground Floor & 1st Floor, Gajularamaram, ALEAP Industrial Area, Pragathi Nagar, Medhcal, Medchal-Malkajgiri - 500 055, Telangana, India,
Tel. : 85007 98350, 81423 98350 & 98481 98350 Mail:martspecialities@gmail.com



DCA Approval No: 05/ML/TS/2020/G

CERTIFICATE OF ANALYSIS

MSL/QA/017-03/F07-00

Name & Address of the Customer:

Tara Government College
Prashanth Nagar Colony, Balajinagar
Sangareddy Telangana. 502000
Contact Person: Dr. Abhijeet
Contact Number :9502344392

Reference / Report No. : MSL/2022/JUNE/TARA/0064-2
Sample Received Date : 11/06/2022
Report Date : 13/06/2022

DETAILS OF THE SAMPLE

Sample Name : NA
Name of the Manufacturer : NA
Batch no : Group-II Mfg. : NA Exp. : NA
Storage condition : To be stored at room date date
Temperature Batch : NA
Room Temperature : 25°C±3°C size
Quantity Received : 4gm
Tests Required : Iron by AAS Analysis.
Method : NA
Analysis Starting Date : 11/06/2022
Analysis Completion Date : 11/06/2022
Mfg. License No. : Not provided
A.R.NO : NA
Remark : Sample analyzed as received

Test Results

S.No.	Test Parameter	Result
01.	Iron by AAS Analysis: (ppm)	832.5ppm

Authorized Signatory

(Dr.R.Marayya)

MART Specialities Lab. LLP

Work : Road No. : 03, Plot No.: 31, Ground Floor & 1st Floor, Gajularamaram, ALEAP Industrial Area,
Pragathi Nagar, Medhcal, Medchal-Malkajgiri - 500 055, Telangana, India,
Tel. : 85007 98350, 81423 98350 & 98481 98350 Mail:martspecialities@gmail.com



DCA Approval No: 05/ML/TS/2020/G

CERTIFICATE OF ANALYSIS

MSL/QA/017-03/F07-00

Name & Address of the Customer: Tara Government College Prashanth Nagar Colony, Balajinagar Sangareddy Telangana. 502000 Contact Person: Dr. Abhijeet Contact Number :9502344392	Reference / Report No. : MSL/2022/JUNE/TARA/0064-3 Sample Received Date : 11/06/2022 Report Date : 13/06/2022
---	---

DETAILS OF THE SAMPLE

Sample Name	: NA	Mfg.	: NA	Exp.	: NA
Name of the Manufacturer	: NA	date		date	
Batch no	: Group-III	Batch		Batch	: NA
Storage condition	: To be stored at room Temperature	size			
Room Temperature	: 25°C±3°C				
Quantity Received	: 4gm				
Tests Required	: Iron by AAS Analysis.				
Method	: NA				
Analysis Starting Date	: 11/06/2022				
Analysis Completion Date	: 11/06/2022				
Mfg. License No.	: Not provided				
A.R.NO	: NA				
Remark	: Sample analyzed as received				

Test Results

S.No.	Test Parameter	Result
01.	Iron by AAS Analysis: (ppm)	756.5ppm

Authorized Signatory

(Dr.R.Marayya)

MART Specialities Lab. LLP

Work : Road No. : 03, Plot No.: 31, Ground Floor & 1st Floor, Gajularamaram, ALEAP Industrial Area, Pragathi Nagar, Medhcal, Medchal-Malkajgiri - 500 055, Telangana, India,
Tel. : 85007 98350, 81423 98350 & 98481 98350 Mail:martspecialities@gmail.com



DCA Approval No: 05/ML/TS/2020/G

CERTIFICATE OF ANALYSIS

MSL/QA/017-03/F07-00

Name & Address of the Customer: Tara Government College Prashanth Nagar Colony, Balajinagar Sangareddy Telangana. 502000 Contact Person: Dr. Abhijeet Contact Number :9502344392	Reference / Report No. : MSL/2022/JUNE/TARA/0064-4 Sample Received Date : 11/06/2022 Report Date : 13/06/2022
---	--

DETAILS OF THE SAMPLE

Sample Name	:	NA					
Name of the Manufacturer	:	NA					
Batch no	:	Group-IV	Mfg. :	NA	Exp. :	NA	
Storage condition	:	To be stored at room	date		date		
		Temperature			Batch	:	NA
Room Temperature	:	25°C±3°C			size		
Quantity Received	:	4gm					
Tests Required	:	Iron by AAS Analysis.					
Method	:	NA					
Analysis Starting Date	:	11/06/2022					
Analysis Completion Date	:	11/06/2022					
Mfg. License No.	:	Not provided					
A.R.NO	:	NA					
Remark	:	Sample analyzed as received					

Test Results

S.No.	Test Parameter	Result
01.	Iron by AAS Analysis: (ppm)	641ppm

Authorized Signatory

(Dr.R.Marayya)

MART Specialities Lab. LLP

Work : Road No. : 03, Plot No.: 31, Ground Floor & 1st Floor, Gajularamaram, ALEAP Industrial Area,
Pragathi Nagar, Medchal, Medchal-Malkajgiri - 500 055, Telangana, India,
Tel. : 85007 98350, 81423 98350 & 98481 98350 Mail:martspecialities@gmail.com



DCA Approval No: 05/ML/TS/2020/G

CERTIFICATE OF ANALYSIS

MSL/QA/017-03/F07-00

Name & Address of the Customer: Tara Government College Prashanth Nagar Colony, Balajinagar Sangareddy Telangana. 502000 Contact Person: Dr. Abhijeet Contact Number :9502344392	Reference / Report No. : MSL/2022/JUNE/TARA/0064-5 Sample Received Date : 11/06/2022 Report Date : 13/06/2022
DETAILS OF THE SAMPLE	
Sample Name : NA	
Name of the Manufacturer : NA	
Batch no : Group-V	Mfg. : NA Exp. : NA
Storage condition : To be stored at room	date : NA
Room Temperature : 25°C±3°C	Batch : NA
Quantity Received : 4gm	size
Tests Required : Iron by AAS Analysis.	
Method : NA	
Analysis Starting Date : 11/06/2022	
Analysis Completion Date : 11/06/2022	
Mfg. License No. : Not provided	
A.R.NO : NA	
Remark : Sample analyzed as received	

Test Results

S.No.	Test Parameter	Result
01.	Iron by AAS Analysis: (ppm)	807.5ppm

Authorized Signatory

(Dr.R.Marayya)

MART Specialities Lab. LLP

Work : Road No. : 03, Plot No.: 31, Ground Floor & 1st Floor, Gajularamaram, ALEAP Industrial Area,
Pragathi Nagar, Medhcal, Medchal-Malkajgiri - 500 055, Telangana, India,
Tel. : 85007 98350, 81423 98350 & 98481 98350 Mail:martspecialities@gmail.com



DCA Approval No: 05/ML/TS/2020/G

CERTIFICATE OF ANALYSIS

MSL/QA/017-03/F07-00

Name & Address of the Customer: Tara Government College Prashanth Nagar Colony, Balajinagar Sangareddy Telangana. 502000 Contact Person: Dr. Abhijeet Contact Number :9502344392	Reference / Report No. : MSL/2022/JUNE/TARA/0064-6 Sample Received Date : 11/06/2022 Report Date : 13/06/2022
---	---

DETAILS OF THE SAMPLE

Sample Name	: NA				
Name of the Manufacturer	: NA				
Batch no	: Group-VI	Mfg. date	: NA	Exp. date	: NA
Storage condition	: To be stored at room Temperature			Batch size	: NA
Room Temperature	: 25°C±3°C				
Quantity Received	: 4gm				
Tests Required	: Iron by AAS Analysis.				
Method	: NA				
Analysis Starting Date	: 11/06/2022				
Analysis Completion Date	: 11/06/2022				
Mfg. License No.	: Not provided				
A.R.NO	: NA				
Remark	: Sample analyzed as received				

Test Results

S.No.	Test Parameter	Result
01.	Iron by AAS Analysis: (ppm)	708ppm

Authorized Signatory

(Dr.R.Marayya)